



Safety Certificate

Contec Unistar HR Switch Machine with Schaltbau Contacts

Conducted by

To be signed, printed and sent by post.

Thomas Reiter, TUV certified Functional Safety Professional, KConsult GmbH

This report contains 69 pages
(including cover page)

Version 1.0 / January 2011

CONTEC GmbH
Oberahrer Str. 9
56244 Ötzingen - Sainerholz
Deutschland

Conducted by:
KConsult GmbH
Dipl. Phys. Thomas Reiter
D - 88682 Salem
Tel: 07553 9180 210
Fax: 07553 9180 219

BLANK PAGE

TABLE OF CONTENTS

1. REVISION HISTORY	4
2. REFERENCE DOCUMENTS	4
3. RELATED DOCUMENTS	4
4. ABBREVIATIONS	5
5. INTRODUCTION	6
6. RESULT	7
7. SYSTEM DESCRIPTION	8
7.1 OVERVIEW	8
7.2 DETAILED SYSTEM DESCRIPTION	9
7.2.1 Drive system	11
7.2.2 Detection system	13
7.3 FUNCTIONAL DESCRIPTION	20
7.3.1 Initial position on the right	20
7.3.2 Movement towards the right-hand end position	21
7.3.3 Removing the cover on the right	21
7.3.4 Unlocking the right-hand side	22
7.3.5 Locking, covering and left-hand end position	22
7.4 SETTING UP THE SYSTEM	23
8. EVALUATION OF FIELD DATA	24
8.1 NOTES	25
9. OTHER SOURCES OF DATA	25
9.1 ELECTRONIC COMPONENTS	26
9.2 MECHANICAL COMPONENTS	26
9.2.1 Certification of “random failures” state for <i>non-moving</i> mechanical components	27
9.2.2 Treatment of <i>moving</i> mechanical components	27
9.3 HYDRAULIC COMPONENTS	28
10. SIL 4 REQUIREMENTS	28
10.1 PRELIMINARY COMMENTS	28
10.2 REQUIREMENTS	28
11. DEFINITION OF RELEVANT STATES	29
12. FAULT TREES FOR 3, 6, 12 AND 24 MONTH MAINTENANCE INTERVALS	30
12.1 PRELIMINARY COMMENTS	30
12.2 REFERENCE TO PFH AND SIL	31
13. APPENDIX 1: MTTF AND MTTFD DETAILS	32
13.1 SNAP-ACTION SWITCHES	40
13.2 ELECTRIC MOTOR	41
13.3 OTHER ELECTRICS (CABLING)	42
13.4 HYDRAULICS	44
13.5 MOVING MECHANICAL COMPONENTS	45
13.6 NON-MOVING MECHANICAL COMPONENTS	47
14. APPENDIX 2: COMPLETE LIST OF PARTS	48

1. Revision history

Version	Date	Author	Notes
1.0	14.01.2011	Thomas Reiter	Initial version

2. Reference documents

Document	Title
Mil-HDBK-217 FN2	Reliability Prediction of Electronic Equipment
ISO 13849	Safety of machinery -- Safety-related parts of control systems
ISO 61508	Functional safety of electrical/electronic/programmable electronic safety systems
Wiring diagrams	Schaltplan_C-66915.pdf
Parts lists	Komplettstückliste_Unistar_HR.pdf
Drawings	All relevant drawing numbers from C-10057 to C-91151
E-drawing files	IT02000049 DB S49 09.11.10.aktuell.EASM
Schaltbau_S800.pdf	Snap-action switches with positive opening action S800, S804, S814, S820 Series
HR Manual	Manual Finalstatus1_SaoPaulo.pdf

3. Related documents

Document	
Komplettstückliste_Unistar_HR_editTR.xls	Parts list for the Unistar CSV24 system, converted, edited and supplemented with additional information. The last chapter of this analysis (Appendix 2) reproduces the content of this file.
Relex Projektverzeichnis „Contec“	Relex 2009 Project files
FelddatenAuswertung.xls	Excel template for evaluating field data

4. Abbreviations

Abbreviation	Meaning
FIT	Failures In Time = failures per billion [1e9] hours
FMEA	Failure Mode and Effect Analysis
Fpmh	Failures per million [1e6] hours
FR	Failure Rate
GF	Ground, Fixed (Telcordia, Mil-HDBK-217, etc environmental conditions)
HFT	Hardware Fault Tolerance
IEC	International Electrotechnical Committee
ISO	International Standards Organization
MTBF	Mean Time Between Failures (in this analysis: MTBF = MTTF)
MTTF	Mean Time To Failure (in this analysis: MTBF = MTTF)
MTTF _d	Mean Time To <i>dangerous</i> Failure
PFH	Probability of Failure per Hour (SIL requirement in accordance with ISO 61508)
RBD	Reliability Block Diagram

5. Introduction

This report certifies that the

CONTEC Unistar HR Switch Machine

fulfils the

SIL 4 Safety Requirements

Contributors:

Dipl. Ing. Klaus Dieter Best	(CONTEC GmbH)
Dipl. Ing. Markus Wittayer	(CONTEC GmbH)
Dipl. Phys. Thomas Reiter	(KConsult GmbH).

6. Result

This analysis demonstrates that the

CONTEC Unistar HR Switch Machine

fulfils the SIL 4 requirements when maintained at intervals of up to 24 months.

The probability of a system entering a dangerous state is

- not more than $6.99 \cdot 10^{-13}$ after 3 months
- not more than $1.12 \cdot 10^{-11}$ after 6 months
- not more than $1.78 \cdot 10^{-10}$ after 12 months
- not more than $2.85 \cdot 10^{-9}$ after 24 months

The values listed above are maximum values at the end of maintenance intervals (**see Chapter 12**).
The average values over the period are considerably lower.

7. System description

This section describes in detail how the switch machine works.

Because we are dealing with a predominantly mechanical system, it is necessary to describe its operation in some detail, if only because there are no established calculation standards.

A detailed understanding of how the machine works will allow us to develop suitable approaches to safety testing.

You will find further functional descriptions in the latest versions of the operating manuals.

7.1 Overview

The Contec Unistar HR switch machine is an internal prism locking device.

From a safety perspective, this mainly mechanical system comprises two subsystems, which are referred to in this document as

- the functional or drive system and
- the detection system

In combination these represent a dual-redundant mechanical system.

However, as the detailed system description below shows, the interdependencies between the mechanical aspects of the system mean that it cannot be considered a simple 2:1 redundant system, and that it is actually superior to a typical 2:1 arrangement.

— *Even simultaneous individual failures in both subsystems are, from a purely mechanical perspective, highly unlikely to lead to a dangerous system state.*

The two subsystems are mechanically connected only via the target system (the switch points), which means that the detection system is a completely independent entity ensuring and checking the safety of the system.

The system is designed first to move the switch points into the passable position and only then to perform the safety check. If, for some reason, the points are not in the passable position, then the safety check cannot be carried out and downstream systems will be able to detect that the system is in an unsafe state.

This principle is realised mechanically using positive-action drive fittings and locking mechanisms.

The notification of a safe system state (i.e. the switch machine is locked) to downstream systems is carried out by the electrical part of the system using Schaltbau S800 snap-action switches with positive opening action.

The electrical subsystem is functionally embedded in the mechanical detection system.

7.2 Detailed system description

This section describes the safety aspects of the Unistar HR switch machine in its idle state. The order of the descriptions here follows the chronological sequence of functional events described later in the document.

The descriptions mention all the components (including part numbers) required for a basic understanding of the system.

Figure 1 below shows the switch machine installed in a turnout. The cover has been removed. Note the two drive rods (at the top, marked in red) and the two detector rods (at the bottom, also marked in red), which connect the drive system and detection system to the switch points. The hydraulic unit is located outside the rails on the right-hand side and is not shown here.

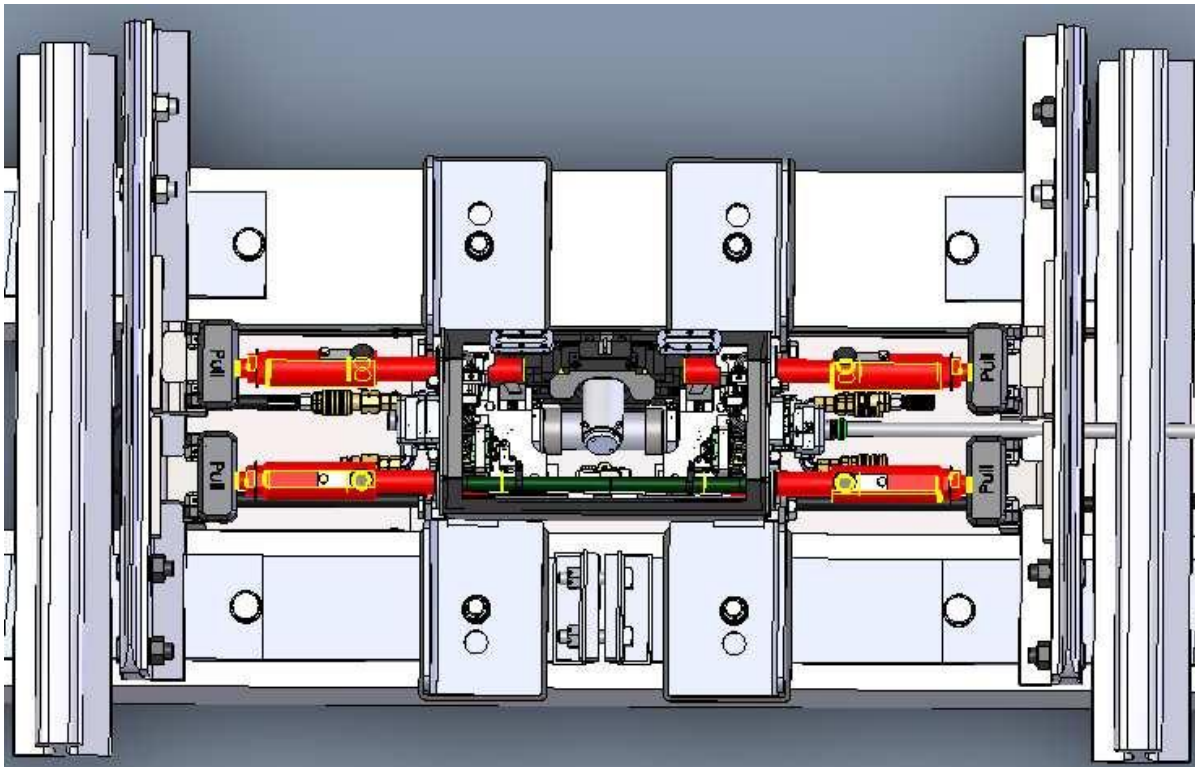

Figure 1

The drive system and detection system are each connected directly and individually to the switch points. This means that the position of the detection system can be changed only by the switch points themselves.

Figure 2 below shows a switch machine similar to the Unistar HR broken down into its functionally-related sub-assemblies. Only the components relevant to safety are shown. The hydraulic unit, points linkage, frame and housing are not shown.

Compared with Figure 1, the position of the switch machine has been rotated through 40 degrees in a clockwise direction here. The sub-assemblies of particular interest in this analysis are clearly visible, namely

- the locking mechanism and drive rods (essentially the drive system)
- the detector mechanism and detector rods (essentially the detection system).

The snap-action switches (embedded in the detector mechanism) are not shown.

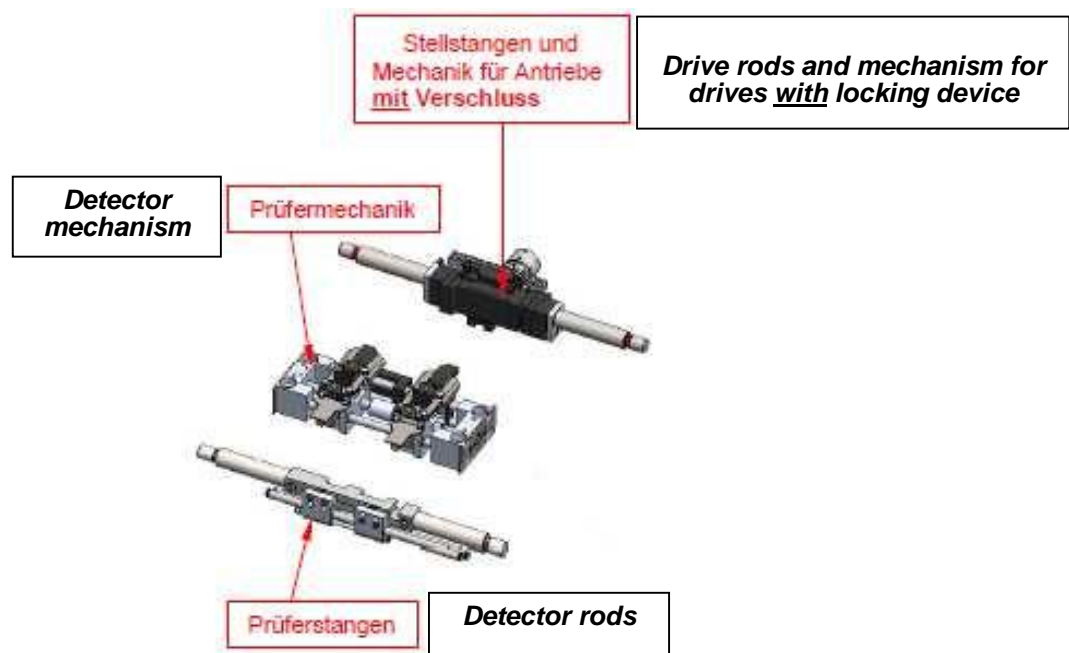

Figure 2

7.2.1 Drive system

Figure 3 shows almost the entire drive system (locking system) both in its assembled form and as an exploded view.

The exploded view in Figure 3 has the same orientation as in Figure 2.

The two sliders to the right and left (numbers 10 and 20) lock into one another and allow lateral movement in relation to each other.

The light-coloured housing (no number) contains a cup spring package.

The housing is firmly screwed to the slider on the left (number 20) and uses the spring bolt (number 70) to push the roller (not shown) into the cut-out of the slider on the right (number 10). This combination holds the two sliders (numbers 10 and 20) firmly together, while still allowing the sliders to move in relation to each other if a lateral force greater than 7000 N is applied. This ensures that the switch machine is not damaged by a vehicle passing through the switch on the wrong track in a trailing-point movement and that the drive system is able to follow the forces applied by the vehicle in a controlled manner. Without this "yield" functionality, the sliders could be regarded as welded together and the spring package and roller as nonexistent. After a vehicle passes through the switch on the wrong track, a standard setting operation is required to restore the switch machine to a safe end position, in which the roller (not shown) once again rests in the groove in the right-hand slider (number 10).

We can also see the two locking prisms (numbers 40) and the slots in the two sliders (numbers 10 and 20) which restrict the movement of the locking prisms to a single direction.

Not shown here are the two (fixed) locking pieces L and R (C-14875 and C-14876), which allow the locking prisms to move out of the sliders, provided the lock has reached a certain position.

We can also see the bevelled edges on the locking plate (number 110, areas marked in light grey: "Fill surfaces with neon yellow paint"). These interlock with the bevelled edge of the respective locking prism and push it out of the corresponding slider.

The force from the hydraulic motor is applied to drive system via a reversible synchronous cylinder and to the locking plate (number 100) using other mechanical connecting parts. The bevelled edges of the locking plate come into direct contact with the corresponding bevelled edges of the locking prisms. The locking prisms transfer the forces directly to the sliders (number 10 and 20) and these in turn via the drive rods (C-15968) to the switch points.

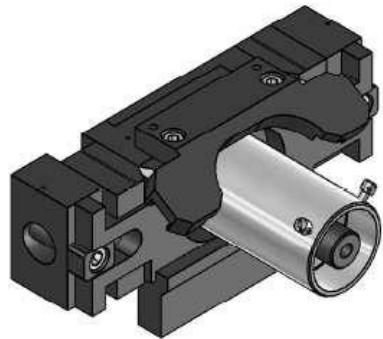
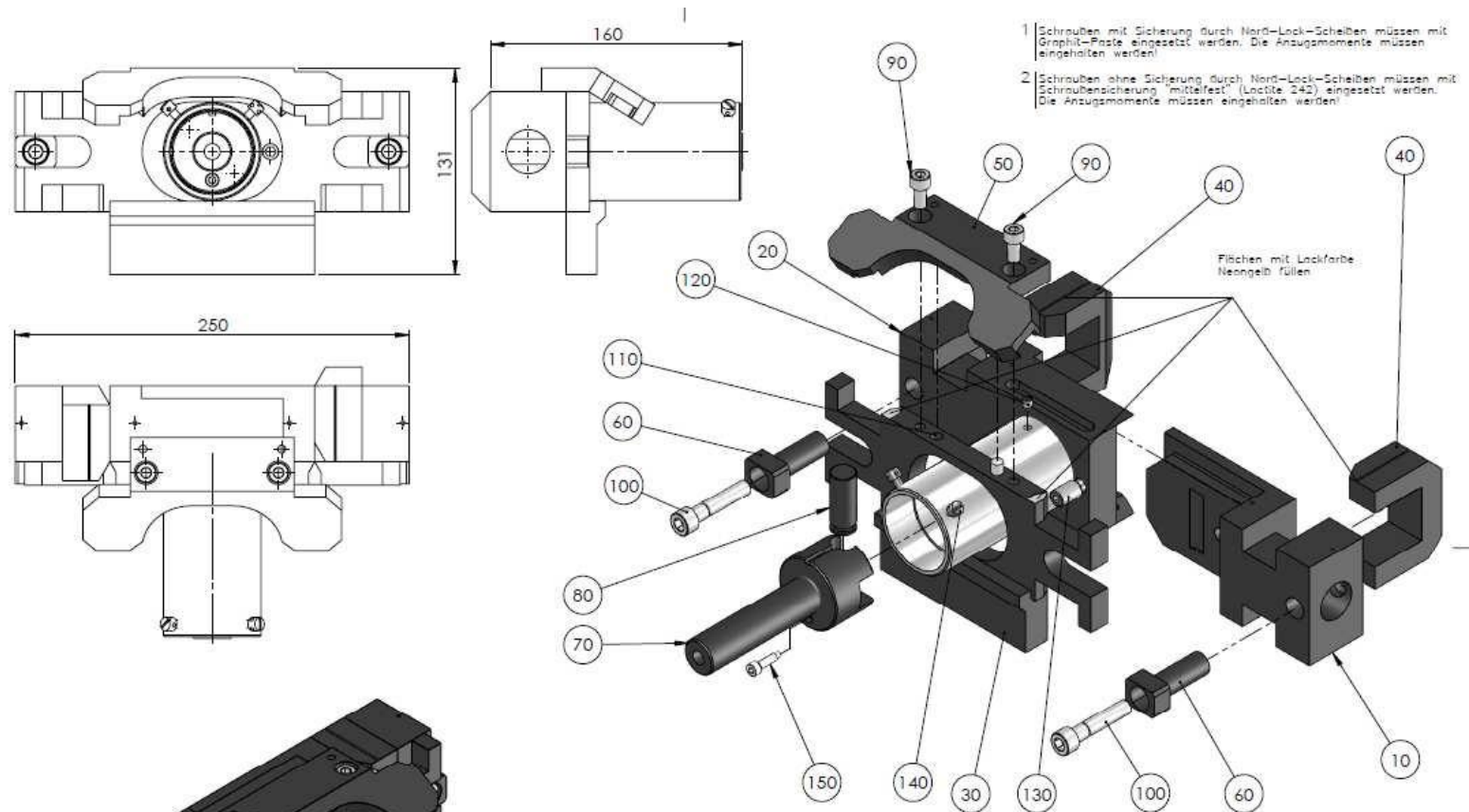

Fertigungsfreigabe	
Datum	Unterschrift
10.05.2010	<i>[Signature]</i>

Verwendbar für: To Use for:	Maße ohne Toleranzangabe: ISO 2768-MH	Toleranzklasse	Größenreihe in mm für Nennmaßbereich in mm							
		m (mittel)	0,5 1/16	3 1/8	6 1/4	30 1 1/2	120 4 3/4	400 15 3/4	1000 39 3/8	2000 78 3/4
Weichenantrieb	Werkstückkanten DIN 6784	Oberfläche DIN ISO 1302	Maßstab: 1:2.5	Art.-Nr.: 67389						
	Datum		Name	Material: ><						
Bearb. Stand Norm	10.08.10	E.Nik	Rohmaß: ><		Gewicht: 11.01					
Benennung:			Verschluss IT-X-AV							
Zeichnungsnummer:			IT02040251							
			Blatt 1 (A3) 1 von 1							

Figure 3

7.2.2 Detection system

Figure 4 shows the right-hand detector slide, which is used to verify the right-hand end position of the points. The left-hand detector slide is identical but is assembled the other way round and used to check the left-hand end position of the points.

The locking device (number 50 in Figure 3) is screwed directly onto the locking plate (number 110 in Figure 3) and, with its special guide geometry, acts against the force of the spring (number 80) directly onto the locking dogs (number 20) on the detector slide (Figure 4), which itself has matching geometry.

The detector slide locking bracket (number 10) is pushed into the slots in the two detector rods (Figure 5) *providing mechanical confirmation* that the appropriate safe end position has been reached.

On the top of the locking bracket (number 10) there is a bolt (number 90) at the front which mechanically activates the snap-action switches.

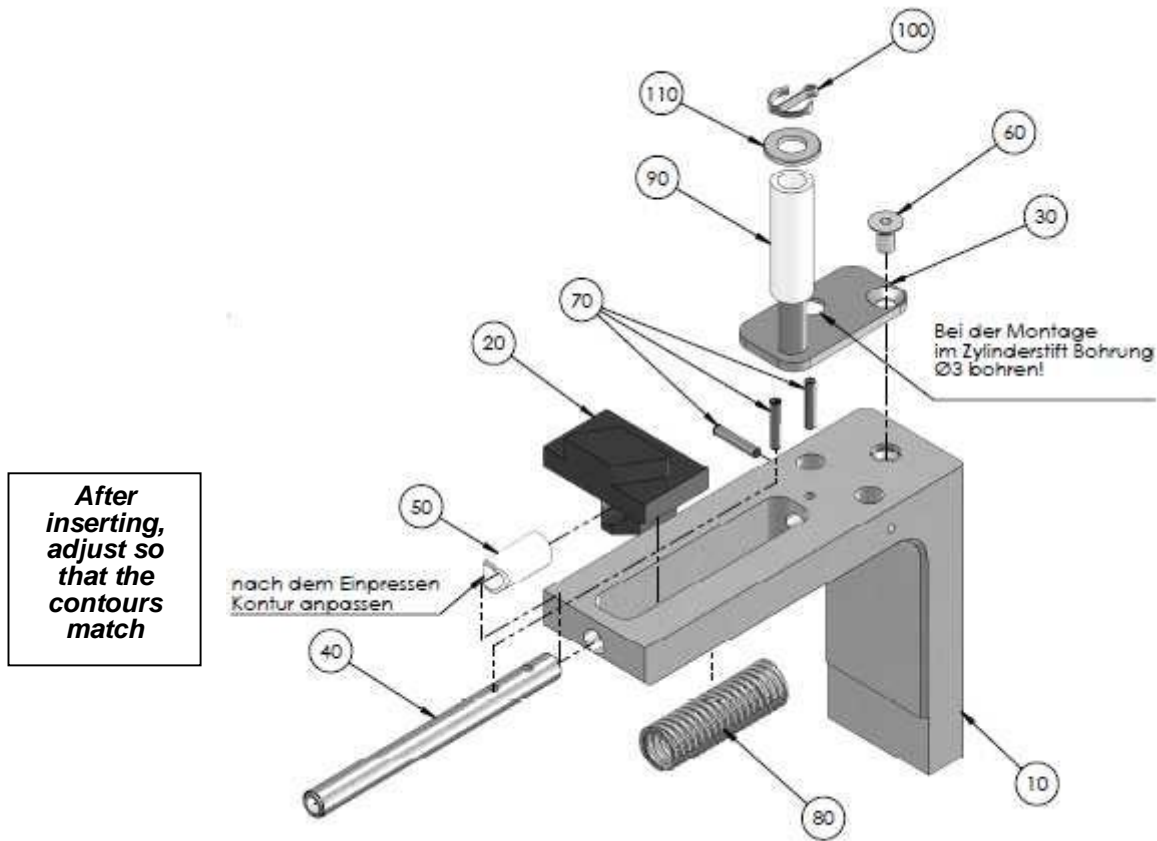

When installing in a cylinder pin, bore a Ø3 hole

Figure 4

Figure 4a:

The bolt (number 90 in Figure 4) operates the snap-action switches.

Shown here is a set of four snap-action switches. The switch machine has two of these sets.

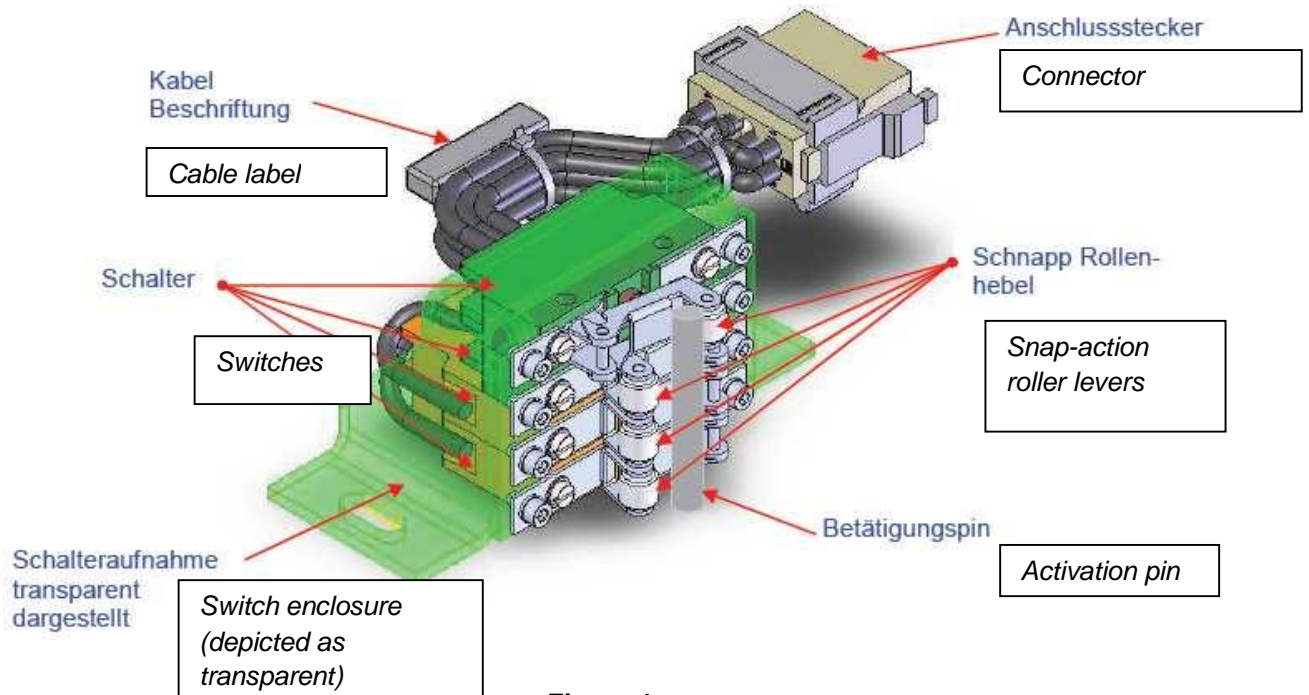

Figure 4a

Figure 5 shows the complete detector rod system with one detector bar in the active position (left) and one in the passive position (right).

The two detector rods (light grey, C-15969) are fixed to the outer ends of the switch points using other mechanical connection pieces. At the inner ends they are connected to the corresponding detector rod plates (dark grey, C-15981).

Both detector rod plates have a cut-out for each end position. The locking device (number 50 in Figure 3) pushes the corresponding detector slide locking bracket (red) into the relevant cut-out, providing mechanical confirmation that the switch is in a safe end position.

The cut-outs for the open point are a little wider in order to facilitate error-free trailing of the points when a vehicle passes through the switch on the wrong track in a trailing-point movement.

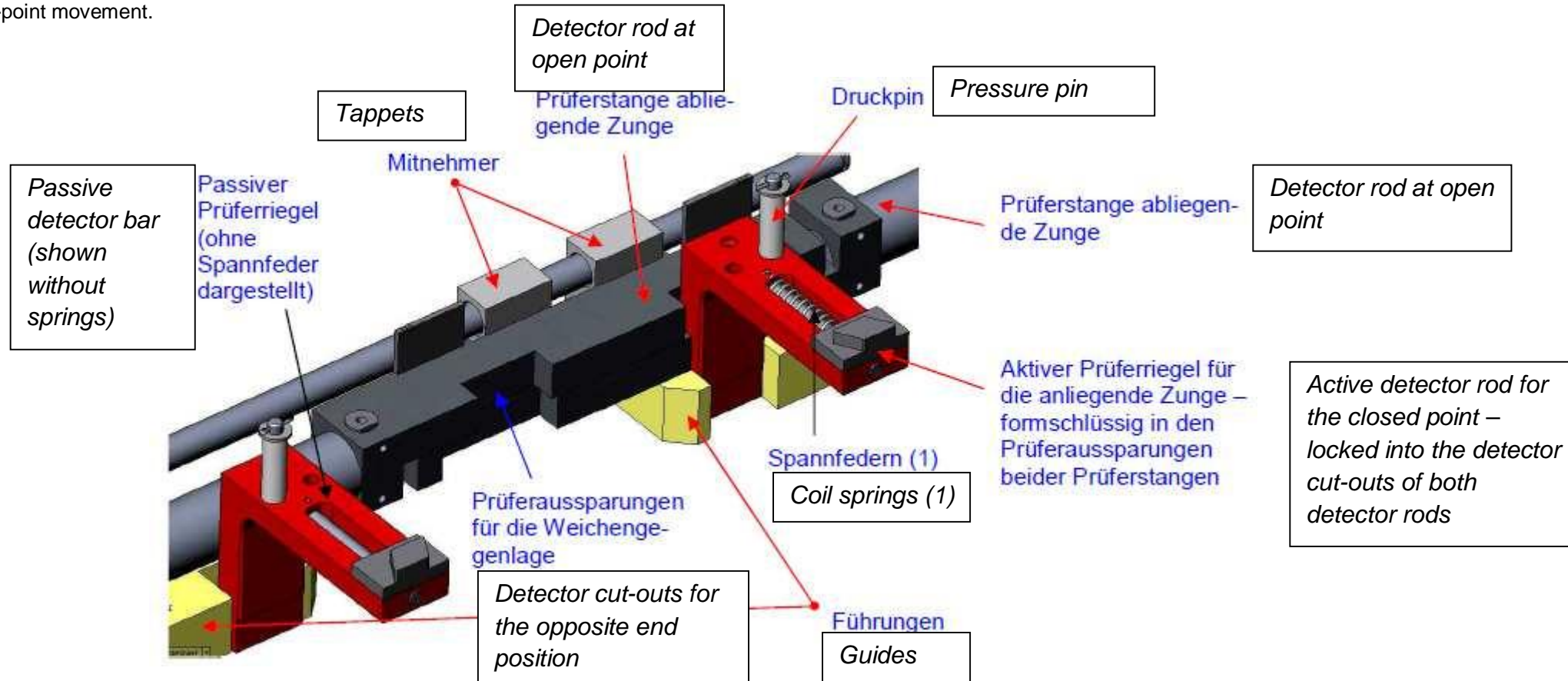

Figure 5

Figure 6 shows the complete detection system once more in context. The system here is in an intermediate setting half-way between the right-hand and left-hand end positions.

The view of Figures 6 and 7 is the same as in Figure 2.

Picked out in red is, among other things, the locking mechanism top right (also number 50 in Figure 3), which is not touching either of the two locking dogs (number 20 in Figure 4).

Because the system is in an intermediate position, both detector bars are in the passive position. It can clearly be seen that neither of the locking brackets is positioned in the cut-outs in the detector rod plates.

The bolts on the locking brackets (not marked), which are used to activate the snap-action switches, are also visible here.

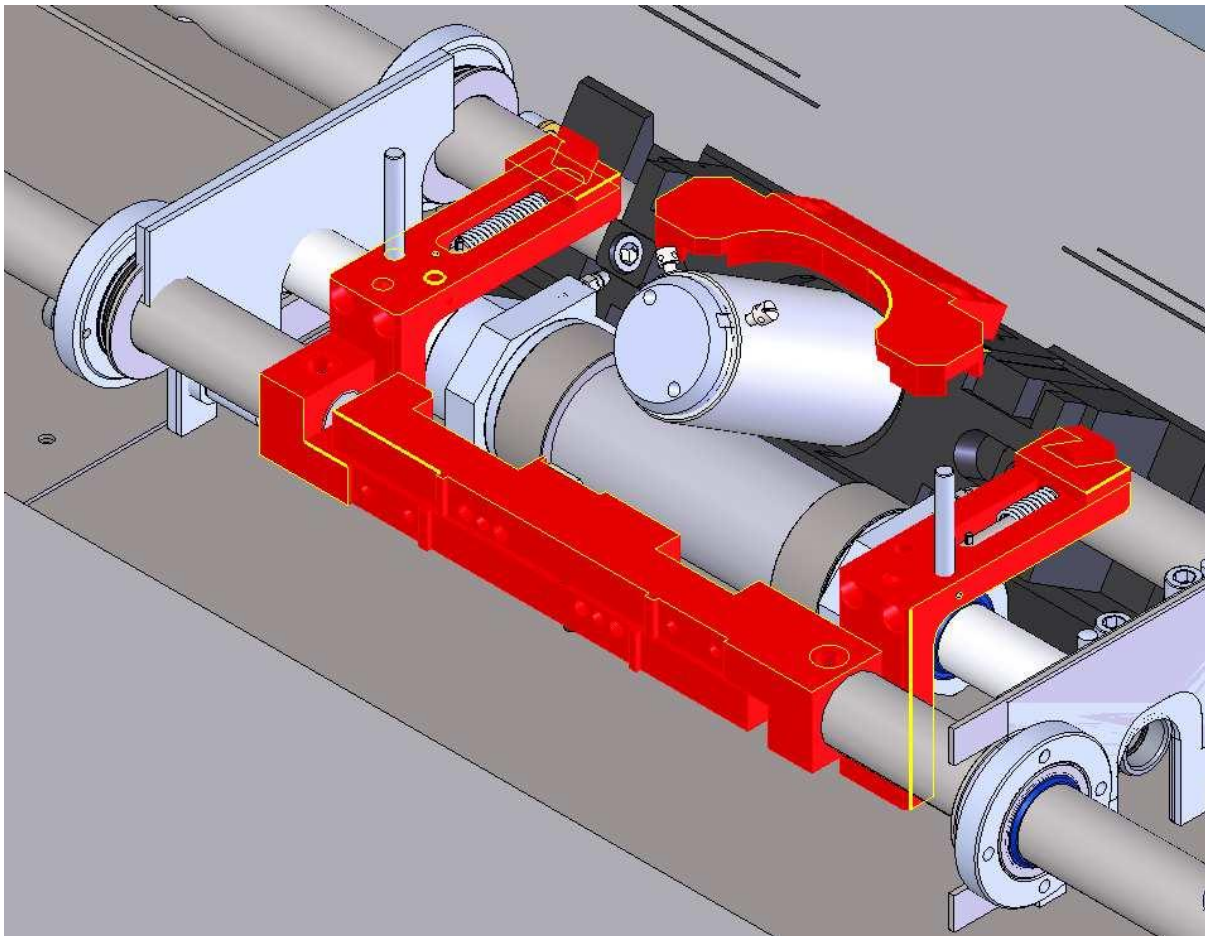

Figure 6

If the cut-outs in the “detector rod plates” (the two components on the bottom left in Figures 6 and 7) are not positioned accurately, the locking device (also number 50 in Figure 3 and the area marked in red in the top right of Figure 6) cannot apply sufficient force to move the detector bars into the position required to activate the snap-action switches.

This is demonstrated by the relative size and diameters of the named components and the dimensions of the active edge of the locking mechanism.

This makes it impossible to “trick” the detection system mechanically if the switch end position is not correct.

Figure 7 shows all the components that were marked in red in Figure 6 plus the contact bolts.

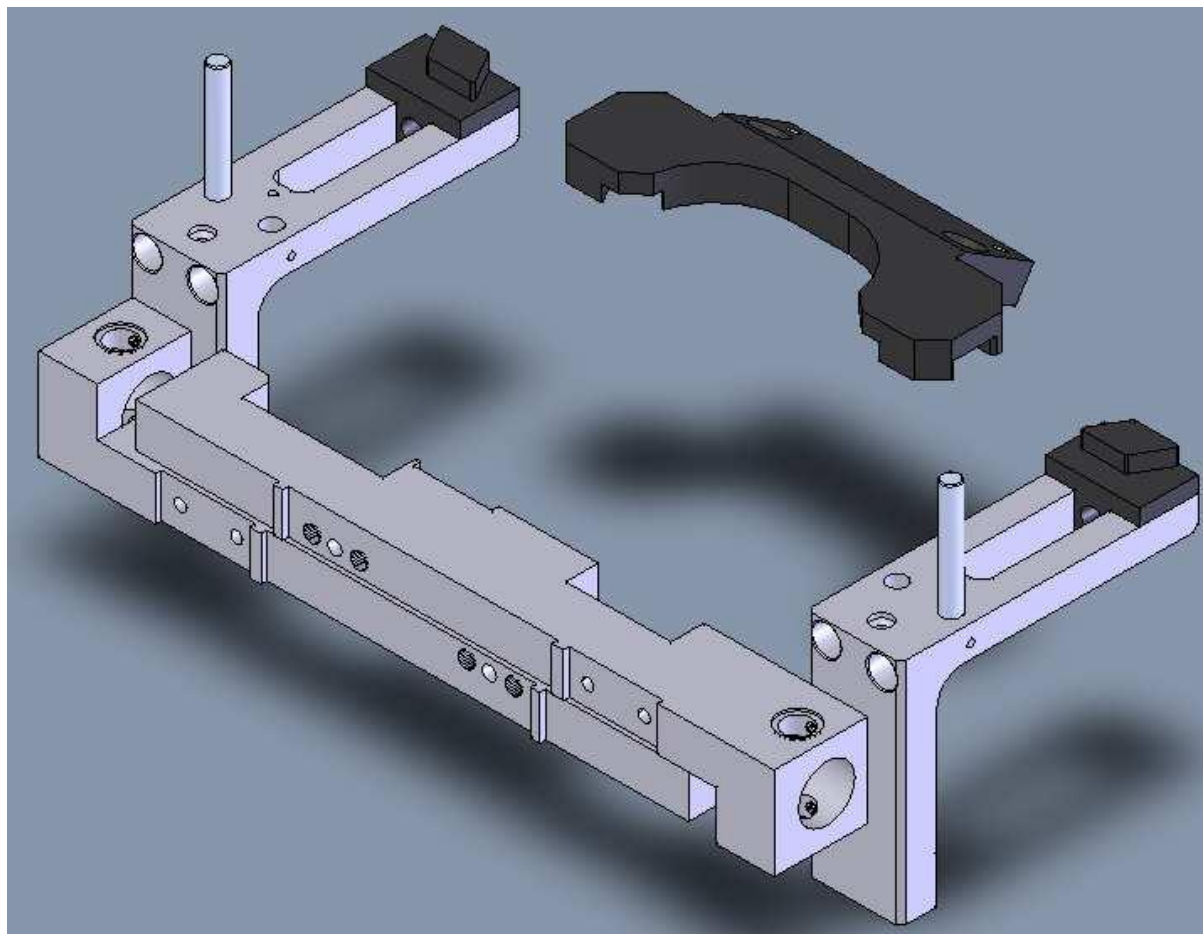

Figure 7

7.3 Functional description

While the operation of the detection system has already been discussed in the preceding system description, the operation of the drive system (locking system) deserves separate consideration of its own.

7.3.1 Initial position on the right

The switch machine is in the right-hand end position, i.e. the points are in the safe passable position on the right and the detection system is in the detection position on the right. Depending on orientation, the snap-action switches are either open or closed. Both sets of snap-action switches (each comprising 4 individual switches) together notify the downstream monitoring system that the switch machine is in the right-hand end position.

Detailed description of the right-hand end position

Figure 8 shows the drive system locking device in the right-hand end position. The picture shows a lock similar to the Unistar HR.

The left-hand prism (red, "Open point prism") is fully retracted into the left-hand slider (yellow) and is secured in position by the upper edge of the fixed prism enclosure (brown, C-14875).

The right-hand prism (red, "Closed point prism") has been slid a little way out of the right-hand slider (green), and its lower bevelled edge touches the bevelled edge of the fixed prism enclosure (turquoise, C-14876).

The locking plate (blue, C-14881) is in the right-hand end position, covering the right-hand locking prism (red) and securing it in its current position.

The right-hand prism is covered by the locking plate and forms the "left-hand stop" for the closed (right-hand) switch point. Together with the right-hand railway track, which here forms the "right-hand stop", this holds the closed (right-hand) switch point securely in this position, subject to the setting of the points gap (see section "Setting up the system") and subject to the yield mechanism described above in relation to a vehicle passing through the switch on the wrong track in a trailing-point movement.

The Allen screws shown on the two sliders form the connections to the drive rods and therefore to the switch points.

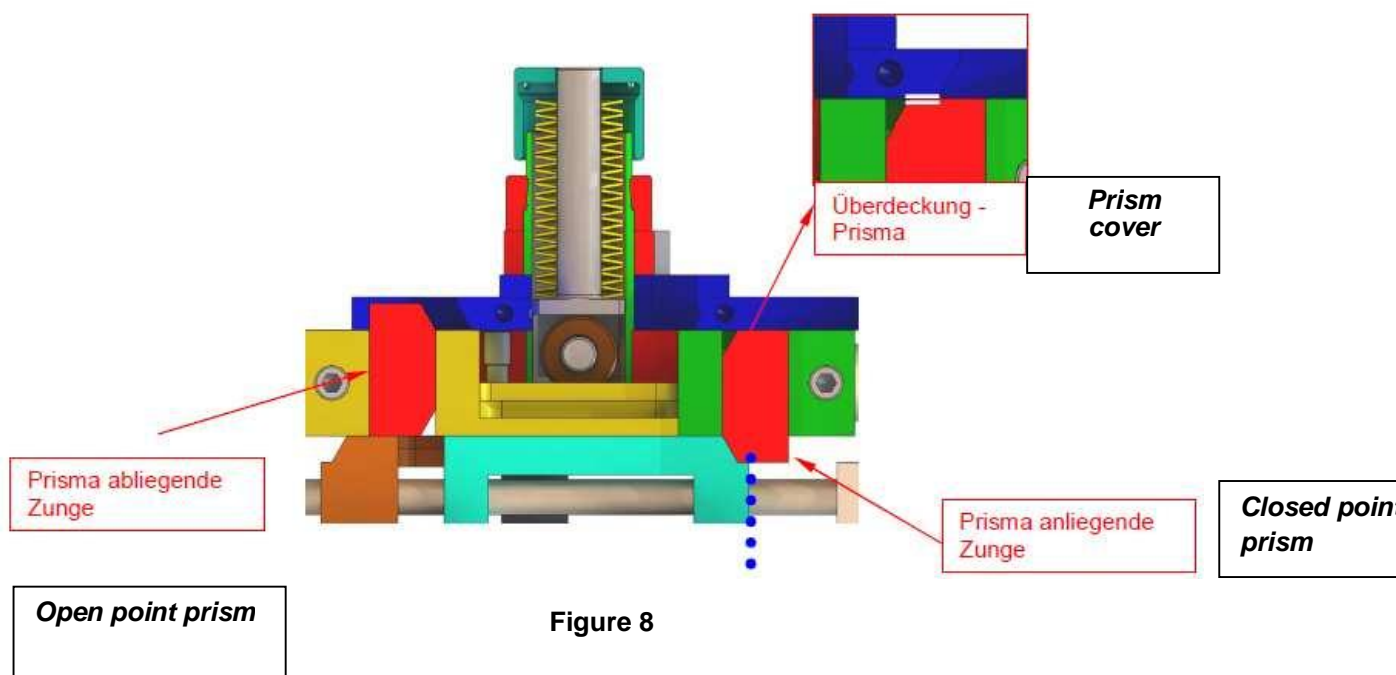

7.3.2 Movement towards the right-hand end position

Figure 9 again shows the drive system locking mechanism in the right-hand end position, this time from the other side. As in Figure 8, the locking plate (in turquoise) which covers the right-hand locking prism (in green), is clearly visible.

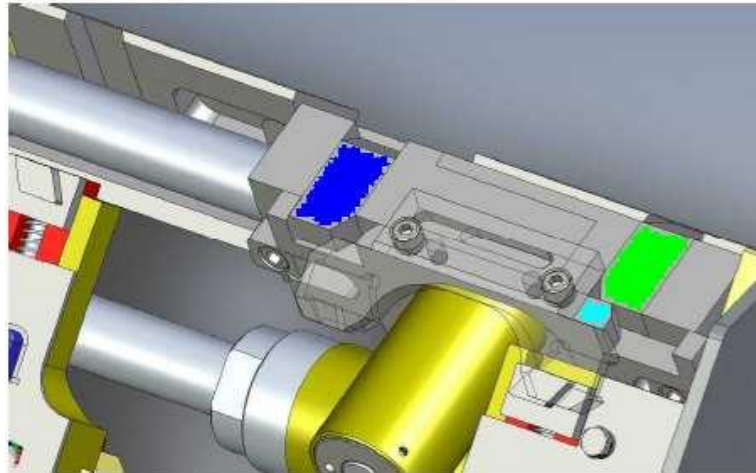

Figure 9

7.3.3 Removing the cover on the right

In Figure 10, the locking plate has moved slightly to the left. The right-hand locking prism (in green) has already been released, but is still fully retracted inside the prism enclosure (turquoise in Figure 8, C-14875). The left-hand locking prism (in blue) is not yet touching the locking plate (turquoise). The direction of movement of the locking plate and the contact between the bevelled edges of the locking plate and the left-hand prism combine to push the left-hand locking prism backwards; however, it is still

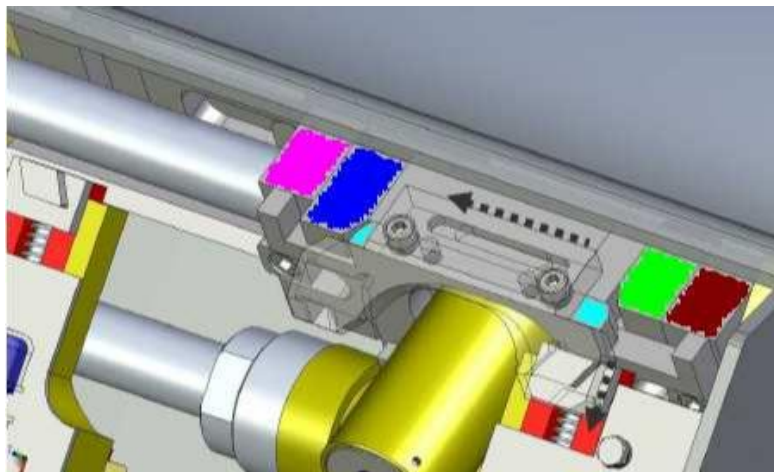

Figure 10

prevented from moving in this direction by the fixed prism enclosure (brown in Figure 8, C-14876). As a result, the force is transmitted via the left-hand locking prism directly to the left-hand slider (pink) and via the spring roller coupling to the right-hand slider (brown), causing the entire lock along with the entire drive system to move towards the left-hand end position.

In the course of the movement between the positions shown in Figures 9 and 10, the locking mechanism mounted on top of the locking plate (not shown, number 50 in Figure 3) has retracted the right-hand detector slide (red) completely from its detector position. See Chapter 7.2.2, "Detection system".

7.3.4 Unlocking the right-hand side

In Figure 11, the locking plate has already moved half-way towards the left-hand end position. The right-hand locking prism (green) has been completely released and, because of the contact between its rear bevelled edge and the corresponding bevelled edge of the fixed prism enclosure (turquoise in Figure 8, C-14875), is already in the unlocked position.

The entire lock and drive systems continue to move towards the left-hand end position.

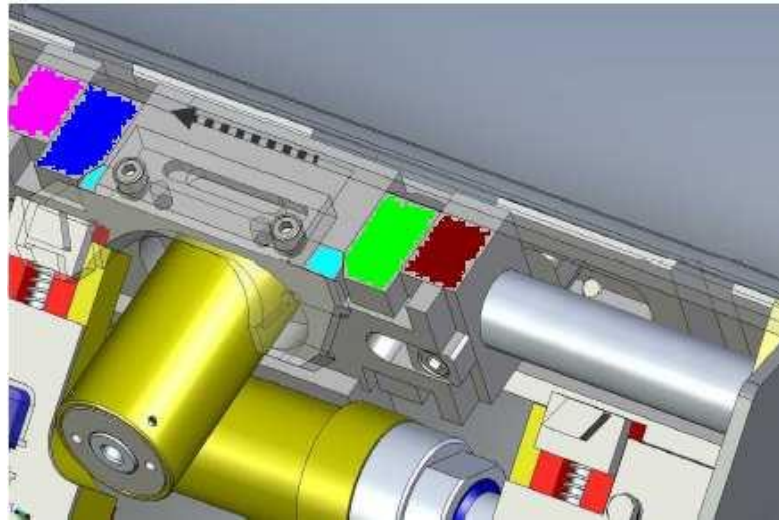

Figure 11

The right-hand locking prism no longer has any special function.

The left-hand edge of the locking plate (turquoise) is already touching the left-hand prism (blue) and will now push it into the fixed prism enclosure (C-14876, brown in Figure 8).

7.3.5 Locking, covering and left-hand end position

Figure 12:

The left-hand locking prism has been pushed into the fixed prism enclosure (brown in Figure 8, C-14876, see arrow). As a result, the left-hand detector slide (red) has been moved into the active position by the locking mechanism (not shown, number 50 in Figure 3). The system is now in the left-hand end position.

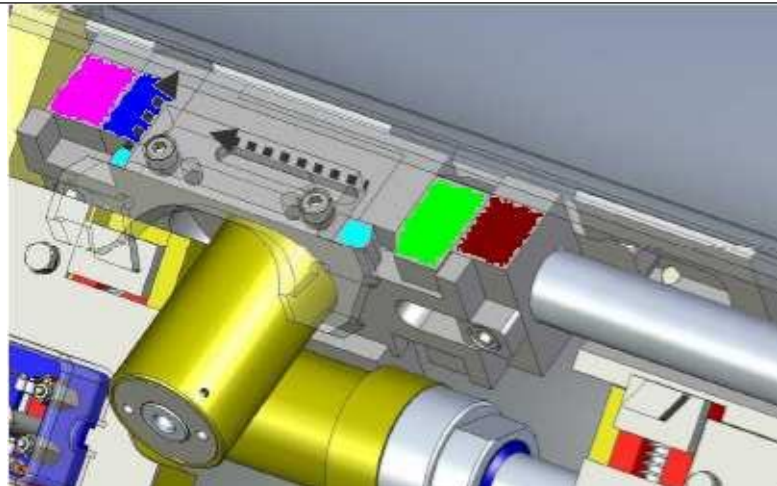

Figure 12

Should one of the prisms jam, the worst case scenario is that the spring-loaded pressure roller will jump out of its groove in the corresponding locking piece and the final end position will not be reached. Because the detection system is directly connected to the switch points, it will always detect this error.

If there is some failure in the hydraulic part of the system, the worst case scenario is that the requested end position is not reached. This is also sure to be detected by the detection system.

7.4 Setting up the system

There are a number of settings that can be made in various places in order to adjust the system. It is not necessary to understand these in detail when considering the safety-related aspects of the system.

The settings are checked using the so-called *gap test*.

This involves placing a metal plate of a defined thickness, usually 4 mm, between the open point and the neighbouring through-rail and then attempting to move the switch machine into this position.

The procedure is then repeated for the other point.

If the switch machine is *unable* to reach the corresponding end position in both cases, then the gap test has been passed.

The gap test is a straightforward test which can guarantee the overall mechanical integrity of the switch machine, as well as identifying circumstances that could lead to the mechanical parts of the switch machine entering an unsafe state.

The gap test is a prescribed component of the routine monitoring carried out by the rail operator and as of December 2010 must be carried out at defined intervals. If the gap test fails, then immediate adjustments must be made, even though there would still be a high degree tolerance (a multiple of the 4 mm) before an unsafe state would be reached.

The gap test is a straightforward, safe, mechanically complete and conservative test. The interval at which it is carried out impacts directly and significantly on the fulfilment of the safety requirements. This will be made clear in Chapter 12, "Fault trees".

8. Evaluation of field data

Field data represent the best possible source of information on system safety and reliability.

As of December 2010 there are around 2,500 similar systems operating in the field.

The average age of these systems is 12 years.

The average number of switches per day is at least 100.

The listed data gives a cumulative operating time of 262,800,000 hours.

It is not known if a CONTEC switch machine has had to be readjusted within its 20-year lifespan due to its having failed a gap test or other reasons. While this cannot be completely discounted from a safety point of view, it does not change the basic reasoning employed in this analysis. CONTEC would almost certainly be aware of any high incidence of readjustment, although even a significantly increased incidence would not necessarily indicate a safety defect because the gap test is both safe and conservative. Furthermore, CONTEC would almost certainly know if a CONTEC switch machine had ever created a potentially dangerous situation.

It is therefore reasonable to conclude that

- The incidence of readjustment is on a par with or better than the generally acknowledged state of the art in the field of railway technology.
- There has so far not been a single incident endangering safety which has been caused by a CONTEC switch machine.

The relationship between cumulative operating time, the $MTTF_d$ to be calculated and statement certainty is given by the following:

$$X^2_{2*(n+1),\alpha} \frac{2 * \text{cumulative_operTime}}{MTTF_d}$$

Where X^2 is the chi square distribution with $2(n+1)$ degrees of freedom and a confidence level of α . n is the number of established dangerous failures and α is the statement certainty of the $MTTF_d$ result.

Assume $MTTF_d$ resolves to $\alpha = 50\%$ and $n=0$

$$MTTF_{d, 50\%} = 379,100,000 \text{ hours}$$

Which, mathematically speaking, represents point estimation.

To be safer still, choose $\alpha = 90\%$ and get

$$MTTF_{d, 90\%} = 114,100,000 \text{ hours}$$

You can easily check this using the CHIINV formula in Microsoft Excel (German Version):

$$MTTF_d = 2 * \text{cumulative_operTime} / \text{CHIINV}(1 - \alpha ; 2 * (n + 1))$$

See also enclosed file FelddatenAuswertung.xls

379,100,000 or 114,100,000 hours are approximately equivalent to between 3 and 10 FIT.

We will make use of this order of magnitude when estimating the failure rates of mechanical components.

It should also be noted that, taken in isolation, the available field data are sufficient only for certification of SIL 4 conformity for a maintenance interval of between 1 and 10 hours. The certification of maintenance intervals up to 2 years can therefore only take place based on theoretical considerations.

8.1 Notes

The considerations in the previous section refer to a duration [h] because the ISO 61508 standard (and all safety standards derived from it) are time-based and the number of operating cycles completed over that period of time is not important.

To apply the results obtained in the previous section to other operating conditions the same calculations are carried out again below, this time based on the number of operating cycles.

As of December 2010 there are around 2,500 similar systems operating in the field.
The average age of these systems is 12 years.
The average number of switches per day is at least 100.

The data above gives a cumulative number of cycles of 26,280,000,000.
The mean number of cycles until a dangerous cycle N_d is given by

$$N_{d,50\%} = 2.64 * 10^{-11}$$

$$N_{d,90\%} = 8.76 * 10^{-11}$$

9. Other sources of data

The CONTEC switch machine comprises mainly (>>90 %) mechanical components with a relatively small proportion of electrical and electronic components.

9.1 Electronic components

There are a number of established standards for calculating the failure rates of electronic components. Mil-HDBK-217 FN2 is the best known and, in terms of results, the most conservative of these. Choosing Mil-HDBK-217 FN2 as the electronics standard for this safety certificate means that we are erring on the side of caution from a safety point of view.

The ANSI/VITA 51.1-2008 (American National Standard for RELIABILITY PREDICTION MIL-HDBK-217 SUBSIDIARY SPECIFICATION) quasi standard has been available since around 2008. This proposes certain modifications to Mil-HDBK-217 FN2 to help achieve more realistic results in 2010 (the results obtained are still military and therefore conservative in nature). This quasi standard has been mostly (but not completely) adopted in this analysis.

In terms of this analysis, this means:

Component type	Selected quality level (PiQ factor)
R,C,L	M (PiQ=1)
Individual semiconductor	B-1 (PiQ=2.4)
ICs	PiQ=3
All other component types	One level better than "Commercial" (PiQ=1....3)

The ambient temperature selected was 80°C (extremely pessimistic) and the environmental conditions were Ground Fixed, Uncontrolled Environment (realistic).

9.2 Mechanical components

There are no standards for mechanical components comparable to those used above for electronics. The only established and accepted sources are

- NSWC-98
- NPRD 95

NSWC-98 was developed for heavy-duty maritime mechanical systems which have to be regularly and intensively maintained. It is characterised by the oft-requested B₁₀ lifespan input data and other parameters which clearly refer to military shipping as a whole. As a result, and because of its limited area of application and internal structure, NSWC-98 is deemed unsuitable for use in this analysis.

NPRD 95 is not a standard but rather a catalogue of field data from several thousand mechanical component types. The data were collected between the 1980s and the early 1990s, meaning that they are similarly outdated to the Mil-HDBK-217 FN2 (which is also from 1995), although this fact alone does not mean they cannot be used. However, NPRD 95 is unsuitable for analysing most of the mechanical components of a switch machine for the following reasons:

- a) A quick look at the failure rates it contains shows that these are an order of magnitude worse than the field data evaluation in the preceding chapter would suggest (not only by a factor of 10 as is the case with Mil-HDBK-217 FN2). The CONTEC switch machine is largely maintenance-free over the course of its expected 20-year lifespan. It is not anticipated that repairs will be required due to defective components in the critical areas of the drive system and detection system.
- b) The components listed in NPRD 95 are to a certain extent generic components found in many different sectors and branches of industry. The characteristic and probably most important components in the switch machine, such as bolts, prisms, sliders and so on, are very specific by comparison and are therefore only very approximately represented (if at all) in NPRD 95 and even then with failure rates that are much too high.

- c) Materials technology, in particular improvements to surfaces, has progressed significantly over the past 20-25 years. Unlike in the field of electronics, where the focus over the same period has been on improving existing processes and increasing the level of integration, the field of mechanics has seen the development of brand new materials and processes. There is no established and accepted source which could be used to adapt NPRD 95 in this direction.

Point a) effectively means that the whole usable lifespan of the switch machine falls in the middle section of the bathtub curve, which in turn indicates a state of purely random failures.

9.2.1 Certification of “random failures” state for non-moving mechanical components

Non-moving components are those which do not move in relation to a neighbouring component and which typically serve only to transmit a force or maintain a certain position.

CONTEC itself has conducted extensive theoretical analyses using the Finite Element Method (FEM), the results of which have led to the implementation of numerous improvement measures which were subsequently verified using practical stress tests. The scope of these analyses and the (partly destructive) stress tests extends far beyond the normal level for the industry. The evidence from the FEM analyses, the stress tests and the scope can be provided or explained by CONTEC at any time. For non-moving mechanical components, these FEM analyses are considered sufficient justification for the assertion that CONTEC switch machines are not expected to suffer any significant failures due to wear and tear over the course of the usable lifespan of the product.

In the analysis below, these components are assigned a nominal FIT / component value and are not considered in any detail. More information can be found in the penultimate and final chapters (appendices) if required. The value of 1 FIT / component is extremely conservative because the evaluation of the field data indicates that the actual value would be significantly lower; however it is still small enough to support the required safety certification.

9.2.2 Treatment of moving mechanical components

Moving components are those that move in relation to a neighbouring component and are therefore subject to function-related frictional forces during their operation. Examples are bolts, prisms, sliders, any components of a rotating axis or whose form is changed (springs, cup springs), and any other components that slide against each other.

While both field data and FEM analyses can be used for non-moving components, FEM methods can be applied only in a very limited sense for frictional effects in moving components. These components are assigned a nominal value of 10 FIT / component in the analysis below and are also explicitly mentioned.

In cases of doubt, mechanical components were categorised as moving. Any inaccuracies resulting from this are negligible in the context of the overall analysis.

9.3 Hydraulic components

NPRD 95 contains data sets that are suitable for use in analysing hydraulic components (even if they are too pessimistic), so these were used.

10. SIL 4 requirements

10.1 Preliminary comments

ISO 61508 can be used as an umbrella standard for all functional safety standards. All other safety standards (most of which are significantly more compact and industry-specific) have been derived from ISO 61508 and share much of its reasoning and terminology.

While ISO 61508 is aimed specifically at electronic systems, there are other derived safety standards (e.g. ISO13849-1:2008) which officially claim to be system-independent, but which on closer inspection clearly focus on electronic systems.

Given that there is no specific set of safety standards suitable for use with the CONTEC switch machine, this analysis uses ISO 61508, insofar as this is reasonable given the nature of the CONTEC switch machine.

10.2 Requirements

1. $10^{-9} \leq PFH \leq 10^{-8}$

The left-hand \leq symbol means that values smaller than 10^{-9} will not be accepted. As already explained above, this requirement implies an extremely short testing interval.

2. $HFT \geq 2$ (Hardware Failure Tolerance)

This means that the system must be able to handle at least two individual failures without compromising the safety function.

This represents the strictest possible interpretation of ISO 61508 for SIL 4 in case other parameters, which are not applicable to the switch machine, have the lowest compliance level. For example, considerations related to the level of diagnostic coverage are not applicable.

11. Definition of relevant states

From a safety point of view, the system has the following safe states:

End position left; End position right.

While these states are somewhat different from a mechanical perspective (proved using FEM), they can be considered similar from a safety point of view. Consequently, the following analysis makes no distinction between left and right.

From a safety point of view, the system has the following dangerous states:

After the request to throw the switch is made, the relevant end position is NOT reached AND this state is either not detected or is wrongly reported to downstream systems as a safe state.

Definition of the safety function:

It should be detected if the system does NOT achieve the desired end position after a request to throw the switch has been made.

Definition of the undesired dangerous state:

The downstream system detects a safe state even though the switch machine is in an undefined state.

Because the downstream system can only detect the state of the switch machine based on the switch positions within specific time frames, all the switches must be in an incorrect state in order to provide the downstream system with dangerous, incorrect information.

Downstream systems that are external to the system under consideration are able to recognise the state of the system only from the state of the switches.

12. Fault trees for 3, 6, 12 and 24 month maintenance intervals

12.1 Preliminary comments

First, all the relevant data for all the relevant subsystems is collected. Source: Appendix 1.

Subsystem	MTTF [h]	MTTF _d [h]	λ_d [fpmh]	Comments
Snap-action switch (1 of)	698,000	698,000	1.43122	MTTF _d = MTTF
Cabling	1,392,000	2,784,000	0.359132	MTTF _d = 2*MTTF
Electric motor	578,000	Infinite	0	
Hydraulics	328,400	Infinite	0	
Moving mechanical parts	1,031,900	2,061,800	0.485	MTTF _d = 2*MTTF Overall 0.9715. Split 50% (0.48575) each between the drive system and detection system
Non-moving mechanical parts	1,027,700	2,055,400	0.4865	

General comments

Although the hydraulics and electric motor are used to drive the system, they are not involved in the configuration of a safe state.

Failure rates for the drive system and detection system are assigned as follows: each subsystem is allocated half the mechanical system failure rate, $0.967 / 2 = 0.4835$.

Downstream systems check the states of the switches within the time windows. These time windows are not taken into account in this analysis, which represents another conservative assumption.

The following events represent the *minimum* criteria for a safety-critical failure:

- an individual failure in the drive system
- an individual failure in the detection system
- an individual failure in at least 4 snap-action switches

or

- an individual failure in the drive system
- an individual failure in the detection system
- 2 individual failures in the cabling

The fault trees clearly show that the HFT ≥ 2 requirement has been met, since only AND gates with at least 4 inputs lead to the undesired Top Event.

12.2 Reference to PFH and SIL

The corresponding SIL 4 requirement of the 61508 standard can be formulated as follows:

$$10^{-9} \leq PFH \leq 10^{-8}$$

Where PFH is the probability of failure after one hour (T=1h in the formula below).

In the context of this analysis this means that the probability of a dangerous state may not have accumulated to more than 10^{-8} at any point between two maintenance intervals.

The relationship to $MTTF_d$ is

$$PFT = 1 - \exp\left(\frac{-T}{MTTF_d}\right)$$

T is the time between two maintenance operations.

In the context of the fault trees, $MTTF_d$ represents the mean time for the overall system to enter a dangerous state, i.e. the logical AND dependencies are already included.

The following fault trees show T = 3 months, 6 months, 12 months and 24 months.

3 months after a maintenance operation the fault tree looks like this:

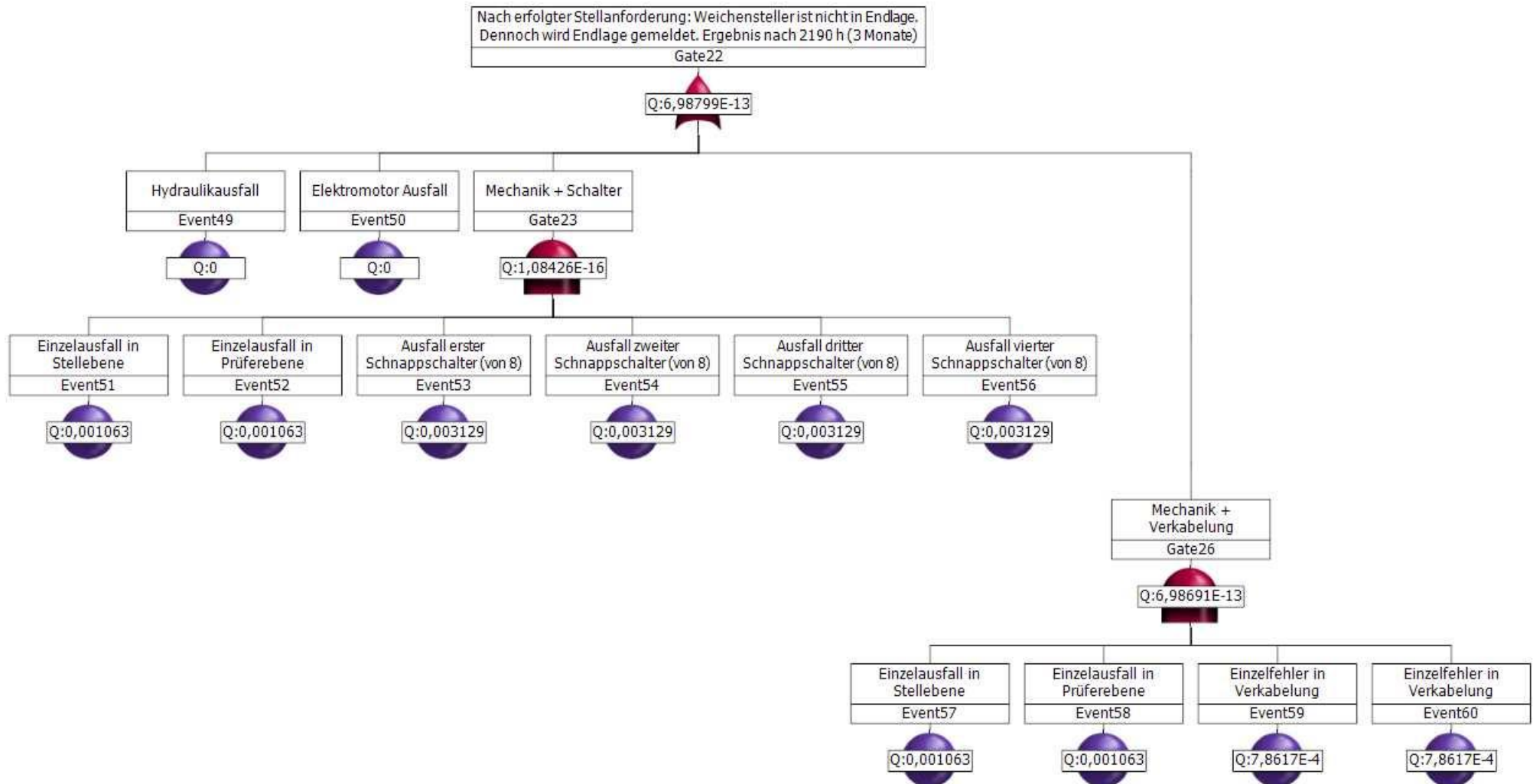

The $\leq 10^{-8}$ requirement is clearly met.

See page 71 for translations of the text in the fault tree.

The probability of a dangerous system state occurring over the period is as follows:

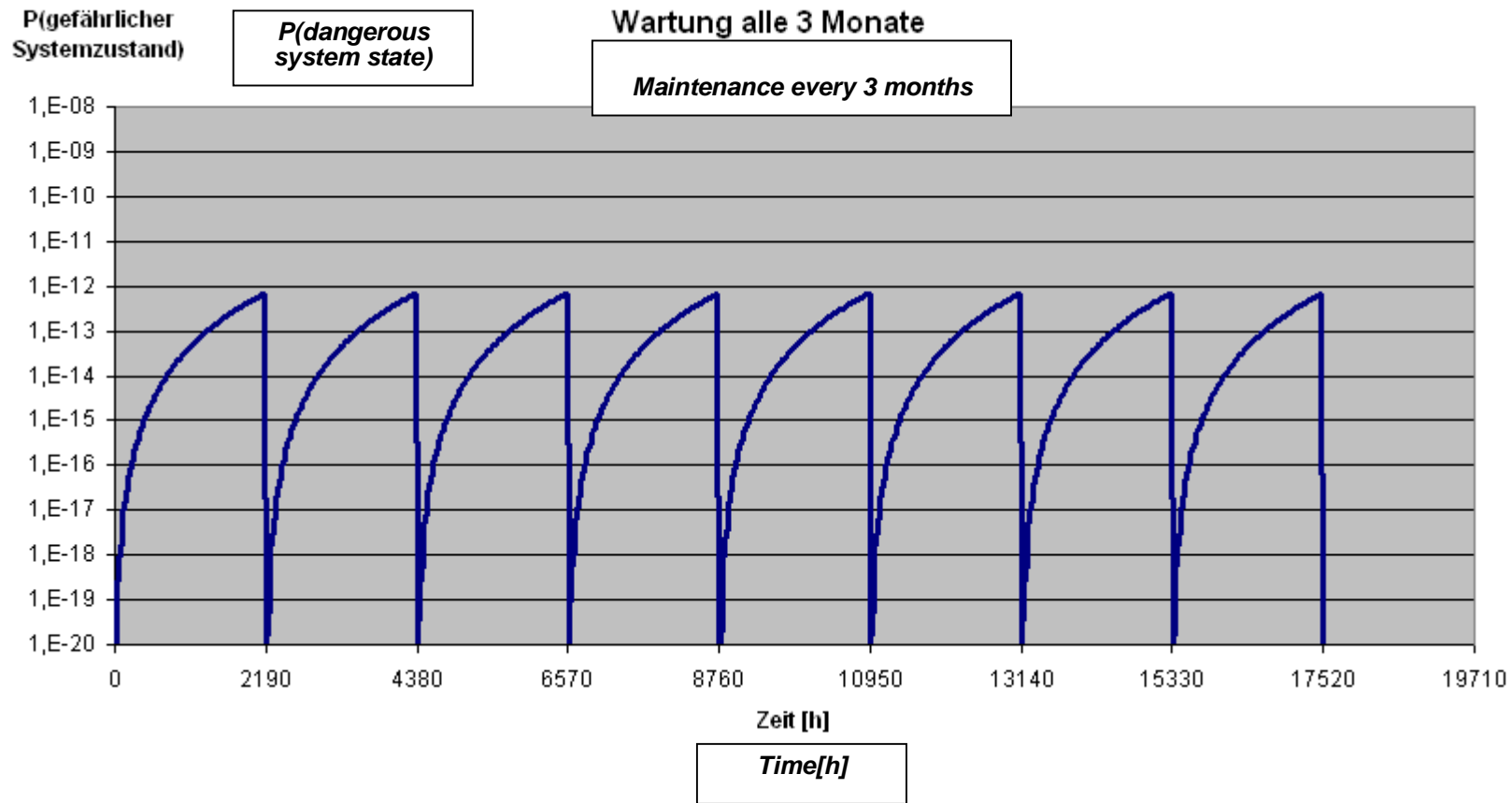

The peak values correspond to the probability of the “Top Event” in the fault tree occurring

6 months after a maintenance operation the fault tree looks like this:

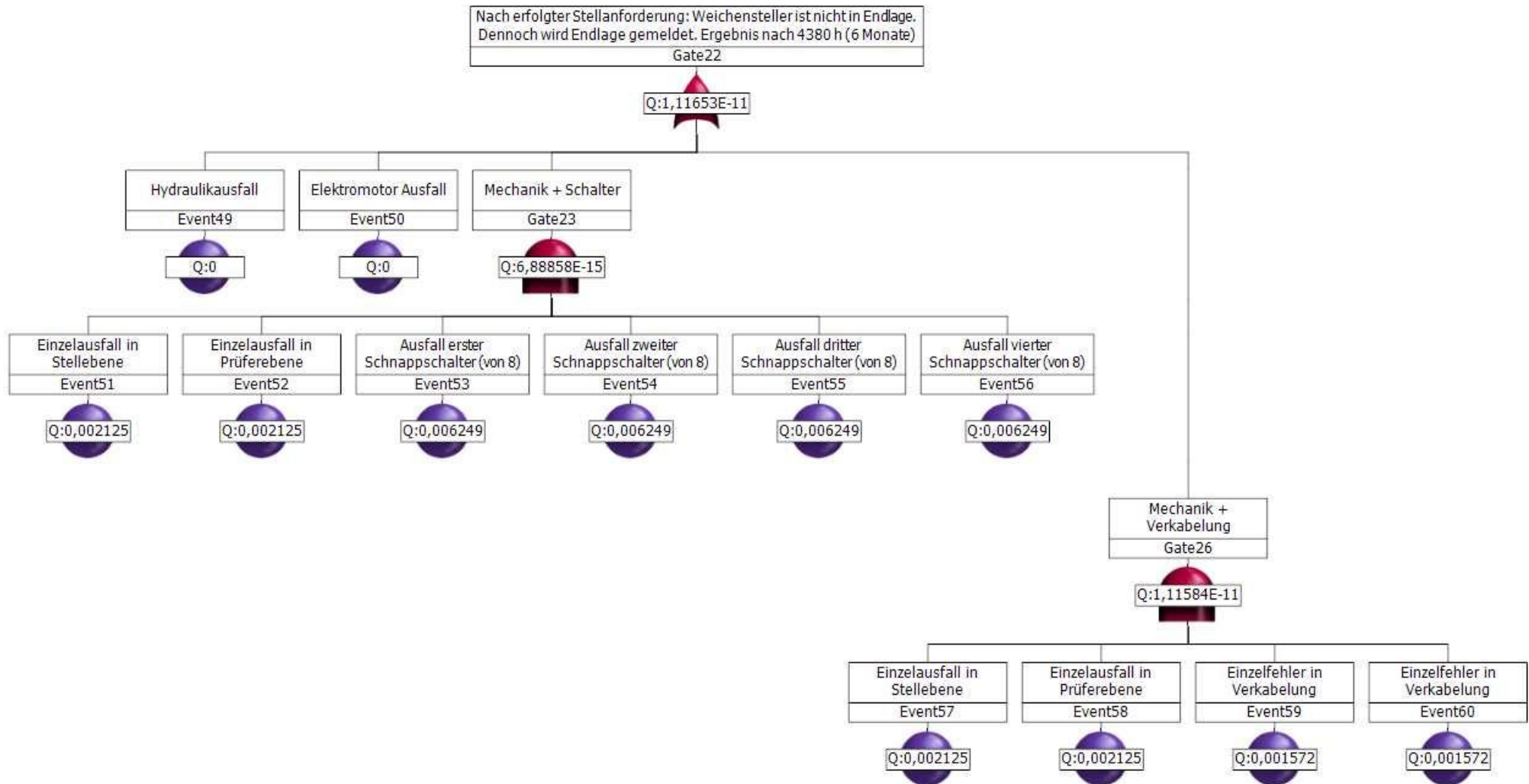

The $\leq 10^{-8}$ requirement is clearly met.

See page 72 for translations of the text in the fault tree.

The probability of a dangerous system state occurring over the period is as follows:

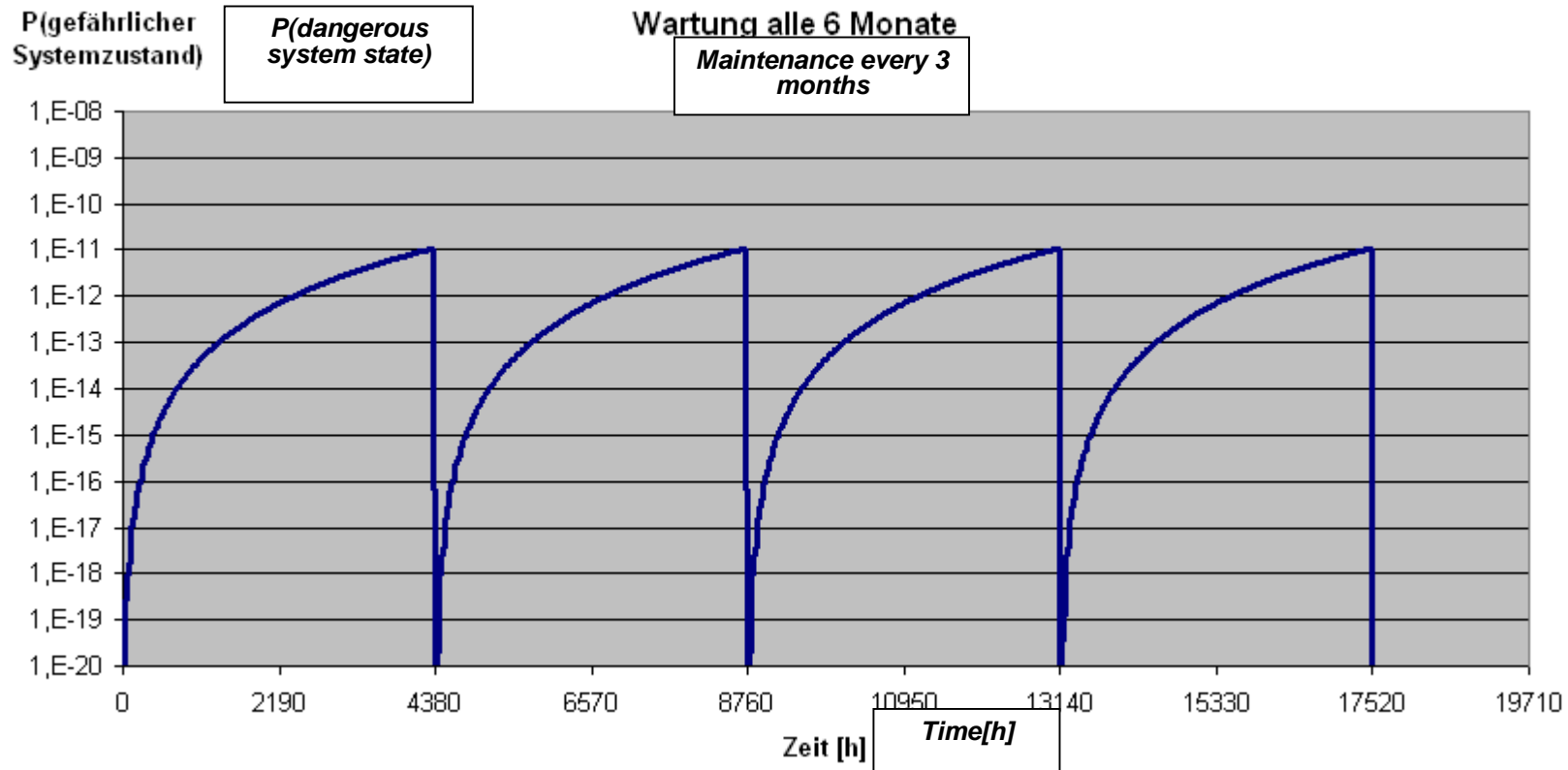

The peak values correspond to the probability of the “Top Event” in the fault tree occurring.

12 months after a maintenance operation the fault tree looks like this:

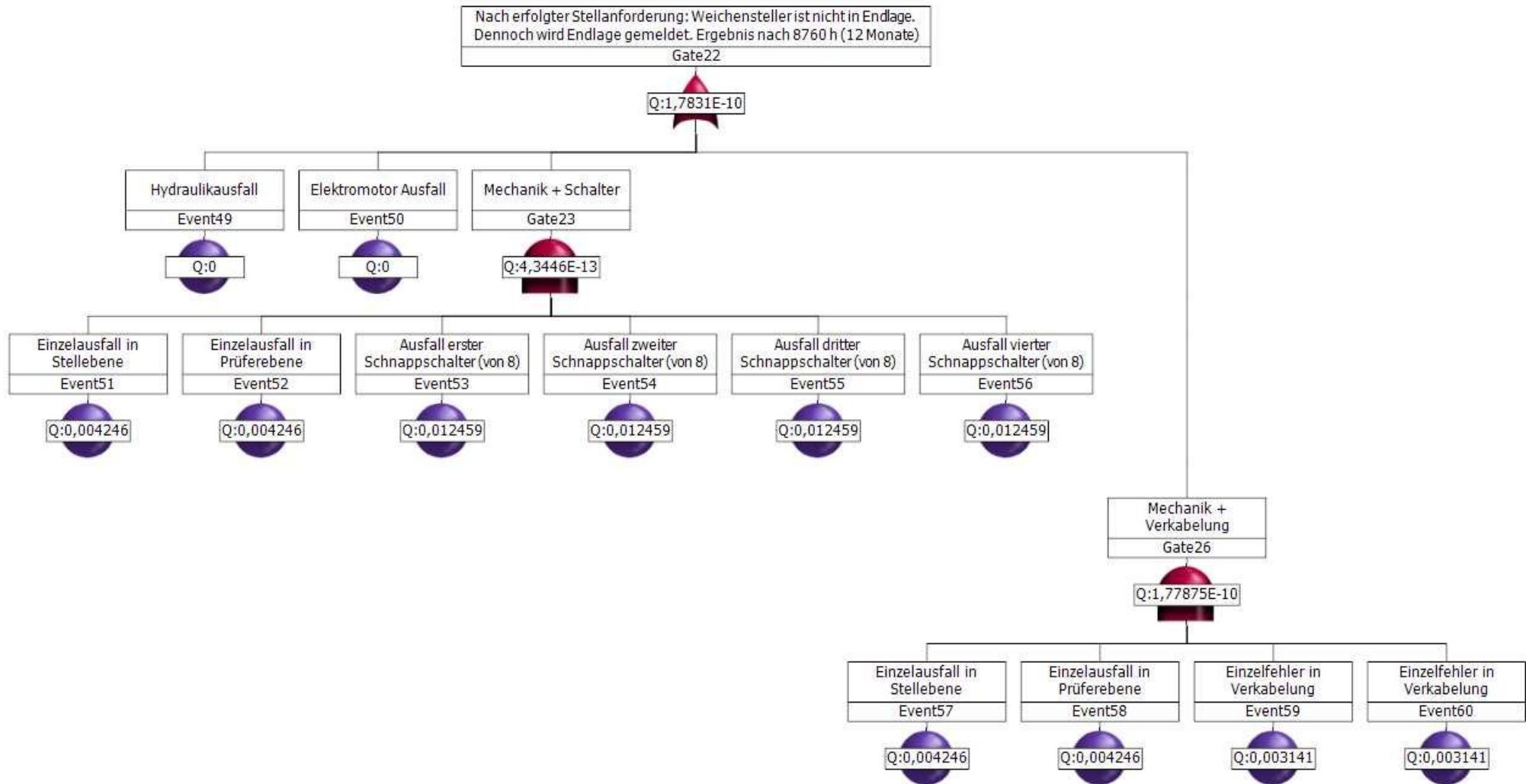

The $\leq 10^{-8}$ requirement is clearly met.

See page 73 for translations of the text in the fault tree.

The probability of a dangerous system state occurring over the period is as follows:

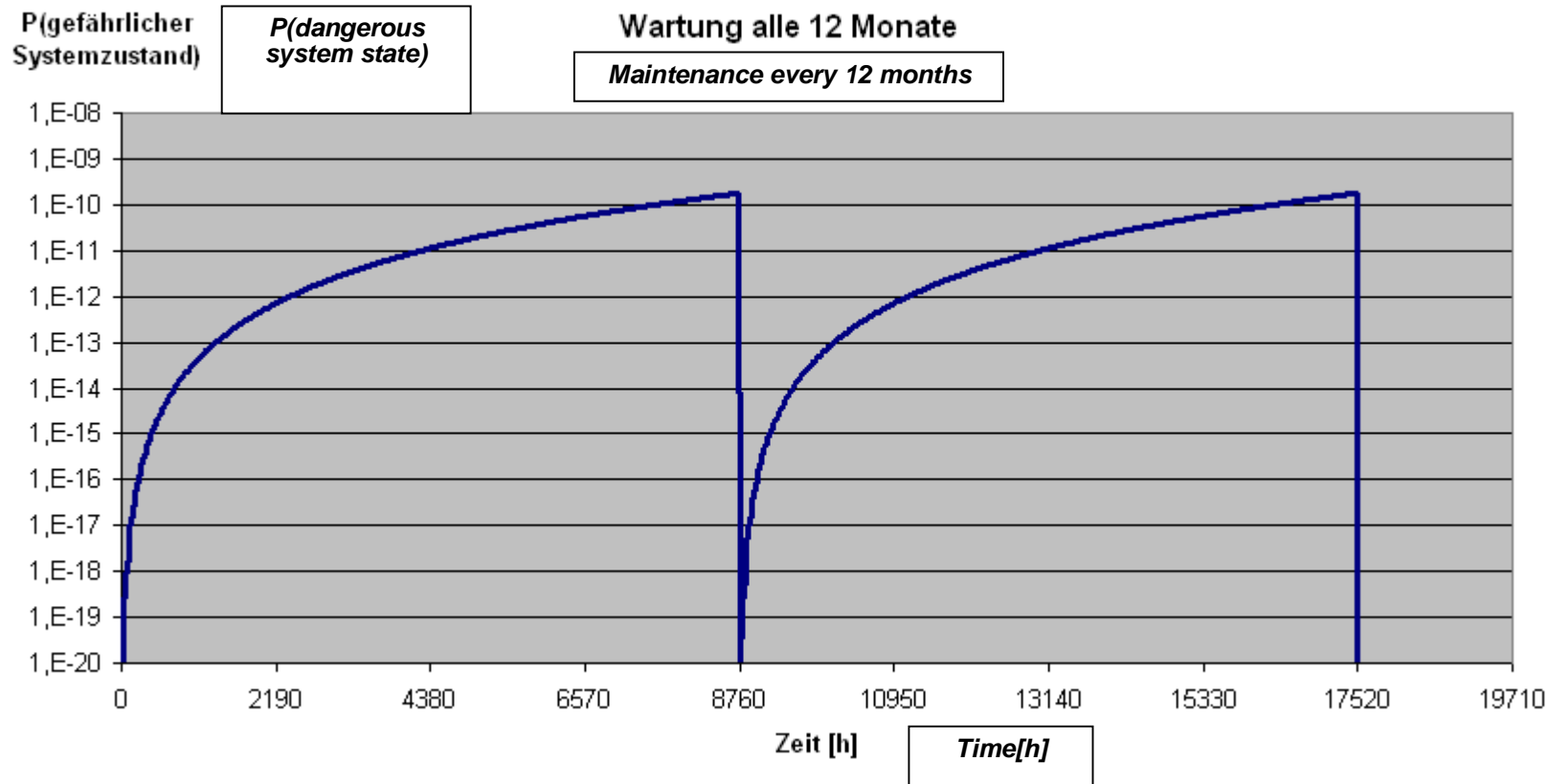

The peak values correspond to the probability of the “Top Event” in the fault tree occurring.

24 months after a maintenance operation the fault tree looks like this:

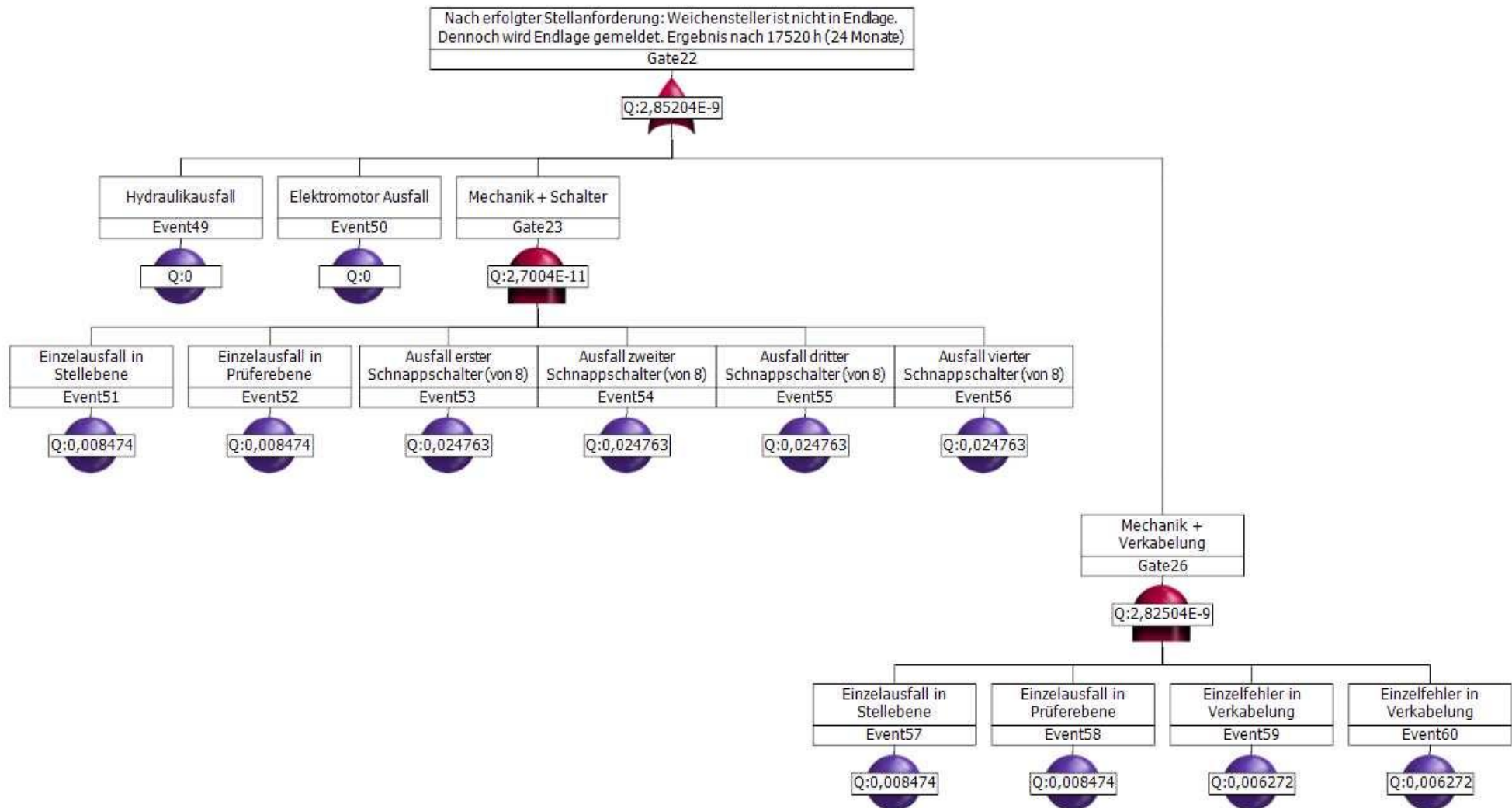

The $\leq 10^{-8}$ requirement is clearly met.

See page 74 for translations of the text in the fault tree.

The probability of a dangerous system state occurring over the period is as follows:

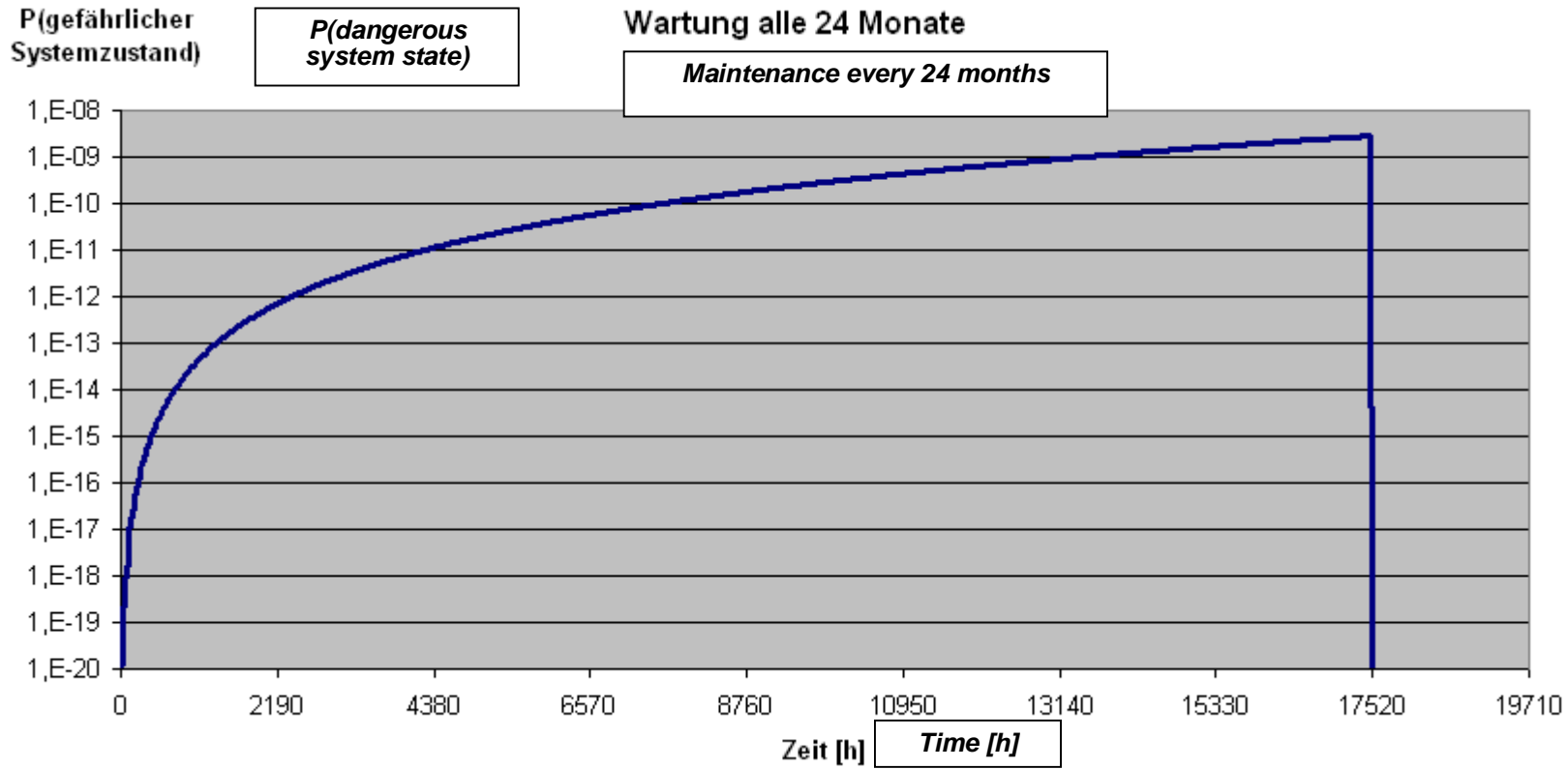

13. Appendix 1: MTTF and MTTFd details

13.1 Snap-action switches

Approach 1a: Calculation based on Mil-HDBK-217 FN2

Calculation: At 80°C, Ground Fixed, Uncontrolled Environment.

Mil-HDBK-217 category: Switch / Pushbutton.

Contact type: SPST (1xIn or 1xOut)

Load type: Inductive. Quality level: "Commercial" ~ PiQ=2

(Recommendation taken from "quasi standard" ANSI/VITA 51.1-2008 : American National Standard for RELIABILITY PREDICTION MIL- HDBK-217 SUBSIDIARY SPECIFICATION for commercial components)

Result: 2.86244 fpmh ~ MTTF = 349,000 h.

Based on the way the snap-action switches are constructed, their qualitative classification as "Commercial" is much too pessimistic.

The next best and most appropriate quality level for switches in Mil-HDBK-217 is "Mil-Spec ~ PiQ=1".

Result with PiQ=1: 1.43122 fpmh ~ MTTF = 698,000 h.

Although this improves the result only by a factor of 2, it represents the maximum that can be achieved using Mil-HDBK-217 without significant interpretation.

Based on their design and construction, a further increase of the MTTF by at least a factor of 10 would be realistic.

Nevertheless, 1.43122 fpmh will suffice for this analysis.

Approach 1b: Calculation based on Telcordia Issue 2

Same as Approach 1a, but using Telcordia Issue 2 (Quality Level 2).

Result: 0.02276 fpmh ~ MTTF = 43,934,000 h.

This is better than Approach 1a by a factor of approximately 70.

For a single snap-action switch, the following would apply:

1.43122 fpmh ~ MTTF = 698,000 h.

13.2 Electric motor

Name	Excel Line	No.	Mil-HDBK-217 category	Description	Failure rate
E- Motor*400VAC*0,7 5KW*1400Upm*B1 4-kl. F	601		Rotating Device	Duty Cycle = 100 switches *3 s /8760 s = 300/8760 = 0.034	1.727851

All values in fpmh for 80°C and Ground Fixed, Uncontrolled Environment.

1.727851 fpmh corresponds to 578,000 hours ~ 66 years.

If the electric motor fails, then in the worst case scenario the switch machine could be part way between the two end positions. However, this state will certainly be recognised by the detection system and the two corresponding inductive sensors. Consequently, a failure of the electric motor cannot lead to a dangerous system state.

This means that the following would apply for the electric motor:

$$MTTF_d = \text{infinite}$$

13.3 Other electrics (cabling)

Because Mil-HDBK-217 FN2 does not cover actual cables (only their contacts), the Chinese standard 299C was used instead.

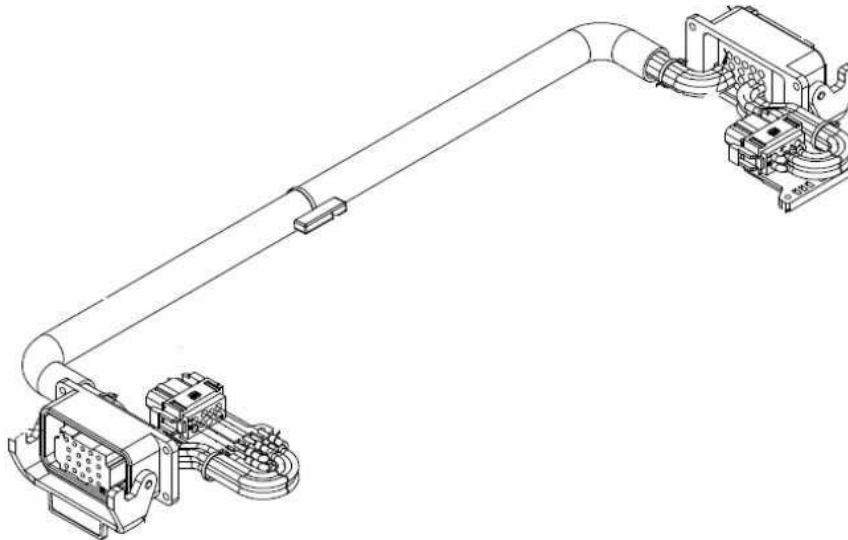

There are a number of ways to handle an electrical system consisting only of connectors and cables. The pessimistic approach is to consider the connectors as a whole (as opposed to considering each individual contact separately).

Bundles of cables are treated as a single cable regardless of the number of individual cores they contain.

Each connector is treated as a "Mated Pair".

Not shown in the picture above are the bridging connector, the connection to the outside world and the two counterparts of the snap-action switches.

This gives the following parts list (all values in fpmh at 80°C and Ground Fixed, Uncontrolled Environment):

Name	No.	Category	Failure rate
Connector for a set of snap-action switches	2	Mil 217 / Connection	0.215132
Connector with bridging connector	1	Mil 217 / Connection	0.107566
External connector	1	Mil 217 / Connection	0.107566
Cable from connector to connector	3	299C / Electric Cable	0.216000
Cable in bridging connector	1	299C / Electric Cable	0.072000
Overall			0.718263

0.718263 fpmh corresponds to 1,392,000 h.

An individual failure in the electrics is not enough to cause a dangerous failure; it requires at least two components to fail in a very specific way to cause a dangerous system failure (and even that is highly unlikely).

This analysis does not take into account the fact that only part of the electrical system is relevant from a signalling point of view.

Based on this, it can be assumed that only a very small proportion of the potential failures can be deemed dangerous, because it would require a very specific constellation of failures to trick the downstream systems into believing the system was in a safe state.

It is reasonable to use the suggestion in ISO 13849:2008, which states that in the absence of a detailed consideration of failure mechanisms, it should be assumed that 50% of all potential failures will be safety-critical.

This means that the following would apply for the cabling:

$$\text{MTTF}_d = 2 * 1,392,000 \text{ h} = 2,784,000 \text{ h} = 414 \text{ years.}$$

13.4 Hydraulics

Name	Excel Line	Description	NPRD 95 category	NPRD 95 data set	No.	Failure rate
Hydraulics						3.044707
<i>NPRD 95. Duty Cycle = 100 switches *3 s /8760 s =300/8760 = 0.034</i>						
Wiper	247	C-87991	Seal	NPRD-9657	4	0.308489
O-Ring47	249	C-87978	Seal	NPRD-9657	4	0.308489
Piston*Dm50/30-IT-02-AV	263	C-15127	Piston	NPRD-8113	1	0.0068
Wiper 30x40x5/8	268	C-88090	Seal	NPRD-9657	2	0.154244
Sliding-Sealing-Ring-Manoy*OMK-MR50-3.2	267	C-80389	Seal	NPRD-9657	1	0.077122
Sealing-Ring30x40x11	269	C-88091	Seal	NPRD-9657	4	0.308489
RVA-06*Non-Return-Valve	274	C-80868	Valve	NPRD-12200	2	0.083042
O-Ring24	275	C-87821	Seal	NPRD-9657	1	0.077122
O-Ring53	276	C-87406	Seal	NPRD-9657	2	0.154244
O-Ring 9.25	491	C-86858	Seal	NPRD-9657	2	0.154244
O-Ring 9.25	496	C-86858	Seal	NPRD-9657	4	0.308489
O-Ring 9.25	502	C-86858	Seal	NPRD-9657	4	0.308489
O-Ring 9.25	507	C-86858	Seal	NPRD-9657	4	0.308489
Gear-Pump*ALP1A-R-4-E1	515	C-88994	Pump	NPRD-8404	1	0.000544
O-Ring51	516	C-80863	Seal	NPRD-9657	1	0.077122
O-Ring200	517	C-81936	Seal	NPRD-9657	1	0.077122
RVB-06*Non-Return-Valve	520	C-80152	Valve	NPRD-12200	2	0.083042
Valve RV1-10N-C-0-18*ABCOTypeMO4/16	527	C-80336	Valve	NPRD-12200	2	0.083042
SPC2-10-N-P-O-100*Non-Return-Valve	523	C-80335	Valve	NPRD-12200	2	0.083042
RVB-08*Non-Return-Valve	521	C-80868	Valve	NPRD-12200	2	0.083042

3.0447 fpmh corresponds to 328,400 h.

If the hydraulics system fails, then in the worst case scenario the switch machine could be part way between the two end positions. However, this state will certainly be recognised by the detection system and the two corresponding inductive sensors. Consequently, a failure of the hydraulics cannot lead to a dangerous system state.

This means that the following would apply for the hydraulics:

$$MTTF_d = \text{infinite}$$

13.5 Moving mechanical components

Moving components are those that move in relation to a neighbouring component and are therefore subject to function-related frictional forces during their operation. Examples are bolts, prisms, sliders, any components of a rotating axis or whose form is changed (springs, cup springs), and any other components that slide against each other.

While both field data and FEM analyses can be used for non-moving components, FEM methods can be applied only in a very limited sense for frictional effects in moving components. These components are assigned a nominal value of 10 FIT / component. Based on available field data (Chapter 8), which indicates a value of between 1 and 10 FIT for the entire system, this represents a conservative approach.

Name	Excel Line	Description	Drwg No.	No.	Failure rate
Moving mechanical components				1	1.39
Guide*Pin*Lock Unistar	119	C-15114	2431131029	2	0.02
Guide*Pin*Lock Unistar	138	C-15114	2431131029	2	0.02
Spring*Shaft*Housing CSV24/PV	14	C-14730	2411000124	2	0.02
Lever*Shaft*HousingCSV24/PV	16	C-14598	2411000117	2	0.02
Flanged*Bush*CSV24/PV	27	C-14606	2411000119	4	0.04
Sliding*Block1*CSV24/PV	39	C-14589	2448100371	1	0.01
Sliding*Block2*CSV24/PV	43	C-14588	2448100370	1	0.01
Locking*Prism*CSV24/PV	45	C-14592	2448100374	2	0.02
Locking*Plate*CSV24/PV	47	C-14593	2448100375	1	0.01
Locking *Mechanism*CSV24/PV	49	C-14612	2448100380	1	0.01
Start*Block*CSV24/PV	51	C-14628	2448100400	1	0.01
Drive*Rod*CSV24/PV~	59	C-14621	2448100389	2	0.02
Spring*Roller	64	C-10475	342120000	1	0.01
Tappet*CSV24/PV	72	C-14652	2448100411	1	0.01
Cup*Spring40X20.4X2.5	86	C-80445		29	0.29
Adjusting*Platform*CSV24/PV	91	C-14609	2448100377	2	0.02
Locking*Piece1*CSV24/PV	93	C-14590	2448100372	1	0.01
Locking*Piece2*CSV24/PV	96	C-14591	2448100373	1	0.01
Guide*Rod*CSV24/PV	98	C-14616	2448100384	3	0.03
Slide*Plate-Detect*Bar*CSV24/PV	107	C-87971	2431131048	4	0.04
Locking*Guide*CSV24/Unistar	108	C-88589	2431131102	2	0.02
Locking*Dogs2 left*CSV24/PV	110	C-15392	2431131112	1	0.01
Locking*Bracket3*CSV24/PV	112	C-15394	2431131113	1	0.01
Locking*Guide*CSV24/PV	115	C-15395	2431131114	1	0.01
Guide*Bolt*CSV24/PV	117	C-14617	2448100383	1	0.01
Locking*Dogs2 right*CSV24/PV	129	C-15393	2431131117	1	0.01
Locking*Bracket3*CSV24/PV	131	C-15394	2431131113	1	0.01
Locking*Guide*CSV24/PV	134	C-15395	2431131114	1	0.01
Compression*Spring*VD-115G*0.7X11.3X84.6	142	C-88512		2	0.02
Pressure*Spring*P117612	143	C-89492		1	0.01
Sliding*Bearing GSM-1633	146	C-87050		2	0.02
Sliding*Bearing GSM-1643	147	C-87109		4	0.04
Sliding*Bearing GFM-1639	148	C-87981		4	0.04
Piston*Rod*CSV24/PV	233	C-15287	2463100045	1	0.01
Grooved*RingT20(AUN-Ring)	284	C-80209		2	0.02

Name	Excel Line	Description	Drwg No.	No.	Failure rate
Detector*Rod2*CSV24/PV~	305	C-14645	2431131053	2	0.02
Detector*Rod1*CSV24/PV~	307	C-14644	2431131052	2	0.02
Guide*Detector*Rod*CSV24/PV~	312	C-14975	2431131089	2	0.02
Sliding*Bearing*GSM-1633	317	C-87050		8	0.08
Spring*Lever*CSV24/PV	324	C-14688	2448100416	1	0.01
Spring*Head*CSV24/PV	326	C-14636	2448100404	2	0.02
Spring*Adjusting*Bolt*CSV24/PV	332	C-14630	2448100403	2	0.02
Spring*Joint*CSV24/PV	334	C-14632	2448100406	2	0.02
Runner*CSV24/PV	338	C-14653	2448100412	1	0.01
SpringISOLamina*WZ8031V-32-115*green	340	C-87988		4	0.04
Sliding*Bearing*GFM-1639	341	C-87981		4	0.04
Sliding*Bearing*GFM-2034	343	C-87979		6	0.06
Sliding*Bearing*GFM-2539	363	C-87983		1	0.01
Sliding*Bearing*GFM-1639	378	C-87981		1	0.01
Sliding*Bearing*GFM-3555	379	C-87023		1	0.01
O-ring 44.12	380	C-80390		1	0.01
Quadring*QRAR04216	381	C-87975		1	0.01
Spring*Bolt	61	C-10474	342100000	1	0.01
Roller*Tappet*Spring*Housing	66	C-10476	342130000	1	0.01

This gives a value of 0.97 fpmh for the moving mechanical components, which corresponds to 1,030,900 h.

It is difficult to estimate what proportion of this 0.97 fpmh is potentially dangerous. However, it is almost certainly very small.

Nevertheless, given the uncertainty, this analysis adopts the approach suggested in ISO 13849:2008, which states that in the absence of a detailed consideration of failure mechanisms, it should be assumed that 50% of all potential failures will be safety-critical.

So the following would apply for the moving mechanical components:

$$MTTF_d = 2 * 1,030,900 \text{ h} = 2,061,800 \text{ h} = 235 \text{ years.}$$

13.6 Non-moving mechanical components

Non-moving components are those which do not move in relation to a neighbouring component and which typically serve only to transmit a force or maintain a certain position. FEM analyses are considered sufficient certification for non-moving components.

All non-moving mechanical components are assigned a nominal value of 1 FIT (0.001 fpmh).

Based on the field data, this represents a conservative approach.

The non-moving mechanical components are not listed separately.

If required, there is more information in the complete list of parts included in the final chapter of this analysis.

This gives an overall failure rate of 973 FIT = 0.973 fpmh, which corresponds to 1,027,700 h.

It is difficult to estimate what proportion of this 0.973 fpmh is potentially dangerous; however, it is almost certainly extremely small.

Nevertheless, given the uncertainty, this analysis adopts the approach suggested in ISO 13849:2008, which states that in the absence of a detailed consideration of failure mechanisms, it should be assumed that 50% of all potential failures will be safety-critical.

So the following would apply for the non-moving mechanical components:

$$\text{MTTF}_d = 2 * 1,027,700 \text{ h} = 2,055,400 \text{ h} = 234 \text{ years.}$$

14. Appendix 2: Complete list of parts

The list of parts is reproduced in full below.

More details can be found in the file Kompletstückliste_Unistar_HR_editTR.xls.

This appendix and the file Kompletstückliste_Unistar_HR_editTR.xls were developed from the original complete list of parts in Kompletstückliste_Unistar_HR.pdf.

Chapter 9 contains an explanation of the terms moving and non-moving.

Level	Item	Exce l Line	No.	Name	Material No.	Drwg No.	Dimensions	Cat 1	Cat 2
		2							
1	10	3		Steel*Support*compl.*S49*1.SE*IT-X-AV	C-66996	IT02070194	SPUR=1435		Purely hierarchical categ.
2	10	4		Steel*Support5*S49*1.SE*IT-X-AV	C-66994	IT02070195	SPUR=1435		Purely hierarchical categ.
3	10	5		Clamping*Block*compl.1*IT-X-AV*S49	C-66989	IT02070187	352X107.5X95		Purely hierarchical categ.
4	10	6	1	Clamping*Block*IT-X-AV*S49	C-15737	IT02070198	352X107.5X60	Mechanical	Non-moving component
4	20	7	1	Holding*Block2	C-15736	IT02070279	90X40X32,5	Mechanical	Non-moving component
5	10	8		Square45x45	C-71070		VKT45		Blank part
3	20	9		Clamping*Block*compl.2*IT-X-AV*S49	C-66990	IT02070305	352X107.5X95		Purely hierarchical categ.
4	10	10	1	Clamping*Block*IT-X-AV*S49	C-15737	IT02070198	352X107.5X60	Mechanical	Non-moving component
4	20	11	1	Holding*Block2	C-15736	IT02070279	90X40X32.5	Mechanical	Non-moving component
5	10	12		Square45x45	C-71070		VKT45		Blank part
3	30	13		Locking*Unit*Bracket3compl.*IT-X-AV	C-66991	IT02070308	728X160X55		Purely hierarchical categ.
4	10	14	1	Locking*Unit*Bracket3*IT-X-AV	C-90350	IT02070306	728X160/15	Mechanical	Non-moving component
4	20	15	2	Bracket4	C-15734	IT02070307	55X40X20	Mechanical	Non-moving component
5	10	16		Flat*Bar40x30	C-70273		40X30		Blank part
3	40	17		Clamp*Block*Bracket*cpl.8*IT-X-AV*S49	C-67476	IT02070392	505X122.5X95		Purely hierarchical categ.
4	10	18	1	Clamp*Block*Bracket2*IT-X-AV*S49	C-90953	IT02070388	505X122.5/15	Mechanical	Non-moving component
4	20	19	1	Bracket6	C-15962	IT02070387	95X40X20	Mechanical	Non-moving component
3	50	20		Clamp*Block*Bracket*cpl.7*IT-X-AV*S49	C-67475	IT02070391	505X122.5X95		Purely hierarchical categ.
4	10	21	1	Clamp*Block*Bracket2*IT-X-AV*S49	C-90953	IT02070388	505X122.5/15	Mechanical	Non-moving component
4	20	22	1	Bracket6	C-15962	IT02070387	95X40X20	Mechanical	Non-moving component
3	60	23		Hydraulic*Unit*Bracket*compl.3*IT-X-AV	C-67031	IT02070284	1470X140X45		Purely hierarchical categ.

Level	Item	Excel Line	No.	Name	Material No.	Drwg No.	Dimensions	Cat 1	Cat 2
4	10	24	1	Hydraulic*Unit*Bracket2*IT-X-AV	C-90409	IT02070283	1470X110/15	Mechanical	Non-moving component
4	20	25	1	Mounting*Plate*IT-X-AV	C-89742	IT02070181	475X45X45/5	Mechanical	Non-moving component
3	70	26	2	Mounting*Plate1*IT-X-AV	C-89736	IT02070162	195X45/8	Mechanical	Non-moving component
3	80	27	2	Mounting*Plate2*IT-X-AV	C-89737	IT02070164	192X42/1	Mechanical	Non-moving component
3	90	28	2	Mounting*Plate3*IT-X-AV	C-89740	IT02070178	120X38X16/3	Mechanical	Non-moving component
3	100	29	2	Mounting*Plate4*IT-X-AV	C-89741	IT02070179	120X40/8	Mechanical	Non-moving component
3	110	30	2	Mounting*Plate5*IT-X-AV	C-89745	IT02070190	122X42/1	Mechanical	Non-moving component
3	120	31	2	Insulating*Plate3*IT-X-AV	C-90328	IT02070304	243X105/3	Mechanical	Non-moving component
3	130	32	2	Support*Plate*IT-X-AV	C-89739	IT02070176	200X62/15	Mechanical	Non-moving component
		33							
3	140	34	2	Safety*Plate	C-90186	IT02070267	190X38X16/3	Mechanical	Non-moving component
3	150	35	2	Insulating*Plate2*IT-X-AV	C-90230	IT02070270	243X105/3	Mechanical	Non-moving component
3	160	36	2	SK*Screw*M20x70	C-90374		M20X70	Mechanical	Non-moving component
3	170	37	6	SK*Screw*M20x80	C-90375		M20X80	Mechanical	Non-moving component
3	180	38	2	SK*Screw*M20x130*ISO4017	C-90469		M20X130	Mechanical	Non-moving component
3	190	39	8	SK*Nut*M20	C-90377		M20	Mechanical	Non-moving component
3	200	40	4	SK*Nut*Flat*M20*FormB*ISO4035	C-81924		M20	Mechanical	Non-moving component
3	210	41	2	SK*Nut*Standalone*M20*ISO10511	C-80036		M20	Mechanical	Non-moving component
3	220	42	4	Safety*Plate*Dm21	C-80683		DM21	Mechanical	Non-moving component
3	230	43	4	Sliding*Bearing MSM2026-20	C-87294		20X26X20	Mechanical	Non-moving component
2	20	44		Steel*Support6*S49*1.SE*IT-X-AV	C-66995	IT02070197	SPUR=1435		Purely hierarchical categ.
3	10	45		Clamping*Block*complete1*IT-X-AV*S49	C-66989	IT02070187	352X107.5X95		Purely hierarchical categ.
4	10	46	1	Clamping*Block*IT-X-AV*S49	C-15737	IT02070198	352X107.5X60	Mechanical	Non-moving component
4	20	47	1	Holding*Block2	C-15736	IT02070279	90X40X32.5	Mechanical	Non-moving component
5	10	48		Square45x45	C-71070		VKT45		Blank part
3	20	49		Clamping*Block*compl.2*IT-X-AV*S49	C-66990	IT02070305	352X107.5X95		Purely hierarchical categ.
4	10	50	1	Clamping*Block*IT-X-AV*S49	C-15737	IT02070198	352X107.5X60	Mechanical	Non-moving component
4	20	51	1	Holding*Block2	C-15736	IT02070279	90X40X32.5	Mechanical	Non-moving component
5	10	52		Square45x45	C-71070		VKT45		Blank part
3	30	53		Locking*Unit*Bracket3compl.*IT-X-AV	C-66991	IT02070308	728X160X55		Purely hierarchical categ.
4	10	54	1	Locking*Unit*Bracket3*IT-X-AV	C-90350	IT02070306	728X160/15	Mechanical	Non-moving component
4	20	55	2	Bracket4	C-15734	IT02070307	55X40X20	Mechanical	Non-moving component
5	10	56		Flat*Bar40x30	C-70273		40X30		Blank part
3	40	57		Clamp*Block*Bracket*compl.8*IT-X-AV*S49	C-67476	IT02070392	505X122.5X95		Purely hierarchical categ.

Level	Item	Excel Line	No.	Name	Material No.	Drwg No.	Dimensions	Cat 1	Cat 2
4	10	58	1	Clamp*Block*Bracket2*IT-X-AV*S49	C-90953	IT02070388	505X122.5/15Har dox400	Mechanical	Non-moving component
4	20	59	1	Bracket6	C-15962	IT02070387	95X40X20	Mechanical	Non-moving component
3	50	60		Clamp*Block*Bracket*compl.7*IT-X-	C-67475	IT02070391	505X122.5X95		Purely hierarchical categ.
4	10	61	1	Clamp*Block*Bracket2*IT-X-AV*S49	C-90953	IT02070388	505X122.5/15	Mechanical	Non-moving component
4	20	62	1	Bracket6	C-15962	IT02070387	95X40X20	Mechanical	Non-moving component
3	60	63		Hydraulic*Unit*Bracket*compl. 4*IT-X-AV	C-67032	IT02070285	1470X140X45		Purely hierarchical categ.
		64							
4	10	65	1	Hydraulic*Unit*Bracket2*IT-X-AV	C-90409	IT02070283	1470X110/15	Mechanical	Non-moving component
4	20	66	1	Mounting*Plate*IT-X-AV	C-89742	IT02070181	475X45X45/5	Mechanical	Non-moving component
3	70	67	2	Safety*Plate1*IT-X-AV	C-89736	IT02070162	195X45/8	Mechanical	Non-moving component
3	80	68	2	Safety*Plate2*IT-X-AV	C-89737	IT02070164	192X42/1	Mechanical	Non-moving component
3	90	69	2	Safety*Plate3*IT-X-AV	C-89740	IT02070178	120X38X16/3	Mechanical	Non-moving component
3	100	70	2	Safety*Plate4*IT-X-AV	C-89741	IT02070179	120X40/8	Mechanical	Non-moving component
3	110	71	2	Safety*Plate5*IT-X-AV	C-89745	IT02070190	122X42/1	Mechanical	Non-moving component
3	120	72	2	Insulating*Plate3*IT-X-AV	C-90328	IT02070304	243X105/3	Mechanical	Non-moving component
3	130	73	2	Support*Plate*IT-X-AV	C-89739	IT02070176	200X62/15	Mechanical	Non-moving component
3	140	74	2	Safety*Plate	C-90186	IT02070267	190X38X16/3	Mechanical	Non-moving component
3	150	75	2	Insulating*Plate2*IT-X-AV	C-90230	IT02070270	243X105/3	Mechanical	Non-moving component
3	160	76	2	SK*Screw*M20x70	C-90374		M20X70	Mechanical	Non-moving component
3	170	77	6	SK*Screw*M20x80	C-90375		M20X80	Mechanical	Non-moving component
3	180	78	2	SK*Screw*M20x130*ISO4017	C-90469		M20X130	Mechanical	Non-moving component
3	190	79	8	SK*Nut*M20	C-90377		M20	Mechanical	Non-moving component
3	200	80	4	SKNut*Flat*M20*FormB*ISO4035	C-81924		M20	Mechanical	Non-moving component
3	210	81	2	SK-Nut*Standalone*M20*ISO 10511	C-80036		M20	Mechanical	Non-moving component
3	220	82	4	Safety*Plate*Dm21	C-80683		DM21	Mechanical	Non-moving component
3	230	83	4	Sliding*Bearing MSM2026-20	C-87294		20X26X20	Mechanical	Non-moving component
2	30	84	1	Connector2forSteelSupport*IT-X- AV Spacer*DM30	C-90368	IT02070316	1620X192X84/2	Mechanical	Non-moving component
		85	2		C-15460	IT02070184	RD30X18	Mechanical	Non-moving component
3	10	86		Round*Bar30	C-70116		RD30		Blank part
2	50	87	4	Vibration*Damper BGONA 30260*	C-89733	MISUMI	D30/M8/M8	Mechanical	Non-moving component
2	60	88	2	SK*Screw*M8x12*ISO4017	C-80128		M8x12	Mechanical	Non-moving component
2	70	89	2	SK*Screw*M8x25*ISO4017	C-80054		M8x25	Mechanical	Non-moving component

Level	Item	Excel Line	No.	Name	Material No.	Drwg No.	Dimensions	Cat 1	Cat 2
2	80	90	4	SK*Screw*M16x20*ISO4017	C-85799		M16X20	Mechanical	Non-moving component
2	90	91	4	SK*Screw*M20x45*ISO4017	C-90937		M20X45	Mechanical	Non-moving component
2	100	92	4	SK*Nut*M8*ISO4032	C-80030			Mechanical	Non-moving component
2	110	93	8	Nordlock*WasherM8	C-86848		DM8.7/13.5X2.5	Mechanical	Non-moving component
2	120	94	8	Safety*Plate*Dm17	C-85742		DM17	Mechanical	Non-moving component
		95						Mechanical	Non-moving component
2	130	96	8	Safety*Plate*Dm21	C-80683		DM21	Mechanical	Non-moving component
2	140	97	2	Bracket2*IT-X-AV	C-15963	IT02070390	348X125X70	Mechanical	Non-moving component
3	10	98		Flat*Bar150x80	C-71085		150X80		Blank part
2	150	99	2	SK*Screw*M20x60	C-90378		M20X60	Mechanical	Non-moving component
2	160	100	4	T-Slot*Nut*Steel8*M20	C-90348	KELLER&K	M20/35X35X28	Mechanical	Non-moving component
2	170	101	2	Adjusting*Plate*10.0mmthick*IT-X-AV	C-90681	IT02070335	50X40/10	Mechanical	Non-moving component
2	180	102	2	SK*Screw*M20x70	C-90374		M20X70	Mechanical	Non-moving component
2	190	103	2	Cylindrical*Pin8x20*ISO2338	C-80667		DM8X20	Mechanical	Non-moving component
2	200	104	1	SK*Screw*M16x45*ISO4017	C-81727		M16X45	Mechanical	Non-moving component
2	210	105	1	Spring*Washer16mm	C-84275		DM16	Mechanical	Non-moving component
2	220	106	2	U-Washer17mm*ISO7089	C-81928		DM17	Mechanical	Non-moving component
2	230	107	4	Cylindrical*Pin8x28*ISO2338	C-80321		DM8X28	Mechanical	Non-moving component
2	240	108	4	SK*Screw*M16x30*ISO4017	C-80369		M16X30	Mechanical	Non-moving component
2	250	109	8	Fitting*Plate0.5mm*forS49	C-90942	IT02070384	92X69/0.5	Mechanical	Non-moving component
2	260	110	4	Fitting*Plate1mm*forS49	C-90943	IT02070385	92X69/1	Mechanical	Non-moving component
2	270	111	4	Fitting*Plate5mm*forS49	C-90944	IT02070386	92X69/5	Mechanical	Non-moving component
2	280	112		Insert*Frame*forSteelSupport*IT-X-AV	C-67458	IT02070372	284X240X20	Mechanical	Non-moving component
3	10	113	2	Square1*with 2xM16	C-15953	IT02070380	20X20X240	Mechanical	Non-moving component
4	10	114		Square20	C-71080		VKT20		Blank part
3	20	115	2	Square2	C-15954	IT02070381	20X20X244	Mechanical	Non-moving component
4	10	116		Square20	C-71080		VKT20		Blank part
1	20	117		Locking*Unit*complete*IT-X-AV*DB	C-67078	IT02040124	1000X297X188.5		Purely hierarchical categ.
2	10	118		Locking*Unit*IT-X/60-160*DB	C-67076	IT02040121			Purely hierarchical categ.
3	10	119		Mechanics*Housing*compl.*IT-X-AV*DB	C-66964	IT02040214	540X280X175	Mechanical	Non-moving component
4	10	120	1	Housing*Trough*IT-X-AV*DB	C-90332	IT02040213	504X280X135/8	Mechanical	Non-moving component
4	20	121	1	Top*Plate1*IT-X-AV*DB	C-15728	IT02040212	280X163X28	Mechanical	Non-moving component
5	10	122		Top*Plate*for*Housing*IT-X-AV*Water*Jet	C-90879	IT02040253	280X163/30		Blank part

Level	Item	Excel Line	No.	Name	Material No.	Drwg No.	Dimensions	Cat 1	Cat 2
4	30	123	1	Top*Plate2*IT-X-AV*DB	C-15922	IT02040252	280X163X28	Mechanical	Non-moving component
5	10	124		Top*Plate*for*Housing*IT-X-AV*Water*Jet	C-90879	IT02040253	280X163/30		Blank part
4	40	125 126	1	Cutout*Plate2forMech.Housing	C-90355	IT02040217	80X39X18.6/3	Mechanical	Non-moving component
4	50	127	2	Strip*IT-X-AV*DB	C-15729	IT02040125	424X12X10	Mechanical	Non-moving component
3	20	128		Locking*Box*Left*IT-X-AV	C-66958	IT02040210	238X189X100		Purely hierarchical categ.
4	10	129	1	Strut*Left*IT-02-AV	C-14861	IT02040013	238X100X24	Mechanical	Non-moving component
5	10	130		Flat*Bar110x30	C-71035		110X30		Blank part
4	20	131	1	Prism*Enclosure*Left*IT-02-AV	C-14875	IT02040031	165X64X45	Mechanical	Moving component
5	10	132		Flat*Bar70x50	C-70766		70X50		Blank part
4	30	133	1	Thrust*Plate*IT-02-AV	C-14874	IT02040030	165X68X24	Mechanical	Moving component
5	10	134		Flat*Bar70x30	C-70873		70x30		Blank part
4	40	135	1	Lock*Enclosure*IT-02-AV	C-14864	IT02040017	140X60X32	Mechanical	Moving component
5	10	136		Flat*Bar50x30	C-70850		50X30		Blank part
4	50	137	5	ISK*Screw*M12x30*ISO4762	C-90316		M12X30	Mechanical	Non-moving component
4	60	138	2	Countersunk*Screw*M10x16*ISO10642	C-90317		M10X16	Mechanical	Non-moving component
4	70	139	5	Nordlock*WasherM12	C-85912		DM13/19.5X2.5	Mechanical	Non-moving component
4	80	140		Cylindrical*Pin8x16*ISO2338	C-81815		DM8X16	Mechanical	Non-moving component
3	30	141		Locking*Box*Right*IT-X-AV	C-66957	IT02040211	238X189X100		Purely hierarchical categ.
4	10	142	1	Strut*right*IT-02-AV	C-14860	IT02040012	238X100X24	Mechanical	Non-moving component
5	10	143		Flat*Bar110x30	C-71035		110X30		Blank part
4	20	144	1	Prism*Enclosure*Right*IT-02-AV	C-14876	IT02040032	165X64X45	Mechanical	Moving component
5	10	145		Flat*Bar70x50	C-70766		70X50		Blank part
4	30	146	1	Thrust*Plate*IT-02-AV	C-14874	IT02040030	165X68X24	Mechanical	Moving component
5	10	147		Flat*Bar70x30	C-70873		70x30		Blank part
4	40	148	1	Lock*Enclosure*IT-02-AV	C-14864	IT02040017	140X60X32	Mechanical	Moving component
5	10	149		Flat*Bar50x30	C-70850		50X30		Blank part
4	50	150	4	ISK*Screw*M12x30*ISO4762	C-90316		M12X30	Mechanical	Non-moving component
4	60	151	2	Countersunk*Screw*M10x16*ISO10642	C-90317		M10X16	Mechanical	Non-moving component
4	70	152	5	Nordlock*WasherM12	C-85912		DM13/19.5X2.5	Mechanical	Non-moving component
4	80	153	2	Cylindrical*Pin8x16*ISO2338	C-81815		DM8X16	Mechanical	Non-moving component
3	40	154		Lock*IT-X-AV	C-67389	IT02040251	250X160X131		Purely hierarchical categ.
4	10	155	1	Sliding*Block*Right*IT-02-AV	C-15908	IT02040127	170X76X48	Mechanical	Moving component

Level	Item	Excel Line	No.	Name	Material No.	Drwg No.	Dimensions	Cat 1	Cat 2
5	10	156		Flat*Bar90x60	C-70779		90X60		Blank part
		157							
4	20	158		Sliding*Block*Left*compl.*IT-02-AV	C-65420	IT02040040	170X159X76		Purely hierarchical categ.
5	10	159	1	Sliding*Block*Left*IT-02-AV	C-14878	IT02040034	170X76X48	Mechanical	Moving component
6	10	160		Flat*Bar90x60	C-70779		90X60		Blank part
5	20	161	1	Bourdon*Tube*IT-02-AV	C-14883	IT02040039	RD62X135	Mechanical	Non-moving component
6	10	162		Pipe(HP) 65x10*H8	C-71018		DM65/45		Blank part
4	30	163	1	Locking*Plate*IT-02-AV	C-14881	IT02040037	238X116X25	Mechanical	Moving component
5	10	164		Flat*Bar120x30	C-71025		120X30		Blank part
4	40	165	2	Locking*Prism*IT-02-AV	C-14882	IT02040038	76X60X30	Mechanical	Moving component
5	10	166		Flat*Bar70x40	C-70050		70X40		Blank part
4	50	167	1	Locking*Mechanism*IT-02-AV	C-14886	IT02040043	164X73.4X36	Mechanical	Moving component
5	10	168		Flat*Bar90x60	C-70779		90X60		Blank part
4	60	169	2	Drive*Rod*Bolt*IT-02-AV	C-14880	IT02040036	RD30X56	Mechanical	Non-moving component
5	10	170		Round*Bar32	C-70126		RD32		Blank part
4	70	171	1	Spring*Bolt*IT-02-AV	C-15907	IT02040126	RD52X135	Mechanical	Continuously applied force
5	10	172		Round*Bar55	C-70532		RD55		Blank part
4	80	173	1	Roller*Pin*forSpringHousing	C-15909	IT02040128	DM17X44	Mechanical	Continuously applied force
5	10	174		Round*Bar20	C-70125		RD20		Blank part
4	90	175	2	ISK*Screw*M8x16*ISO4762	C-81873			Mechanical	Non-moving component
4	100	176	2	ISK*Screw*M10x50*ISO4762	C-80026	M10X50		Mechanical	Non-moving component
4	110	177	2	Cylindrical*Pin8x16*ISO2338	C-81815	DM8X16		Mechanical	Non-moving component
4	120	178	1	Grub*Screw*M6x8*ISO4028	C-80310	M6x8		Mechanical	Non-moving component
4	130	179	1	Grub*Screw*M12x25*ISO4028	C-85128	M12X25		Mechanical	Non-moving component
4	140	180	2	Capstan*Screw*withSlot	C-89803	WATERMA NN	M5x10	Mechanical	Non-moving component
4	150	181	1	ISK*Screw*M5x25*shortened	C-15910	IT02040250	M5X25	Mechanical	Non-moving component
5	10	182		ISK*Screw*M5x25*ISO4762	C-80133	M	M5X25		Blank part
3	50	183		Detector*Rods2*DB*IT-X-AV	C-67510	IT02040130	310X80X62		Purely hierarchical categ.
4	10	184	2	Detector*Rod*Plate2*IT-02-AV	C-15981	IT02040129	275X40X40	Mechanical	Moving component
5	10	185		Square50	C-70911		Vkt50		Blank part
4	20	186	2	Guide*Plate*IT-02-AV	C-14863	IT02040015	70X40X23	Mechanical	Moving component
5	10	187		Flat*Aluminium*70x40	C-70952		70X40		Blank part
		188							

Level	Item	Excel Line	No.	Name	Material No.	Drwg No.	Dimensions	Cat 1	Cat 2
4	30	189	2	Adjusting*Plate*IT-02-AV	C-88318	IT02040016	65X40X3	Mechanical	Non-moving component
4	40	190	2	Blocking*Sleeve*IT-02-AV	C-14937	IT02040049	RD16X43.5	Mechanical	Non-moving component
5	10	191		Round*Bar18	C-70619	RD18	1.7131		Blank part
4	50	192	44	ISK*Screw*M8x25*ISO4762	C-80010			Mechanical	Non-moving component
4	60	193	8	SK*Screw*M6x16*ISO4017	C-80442			Mechanical	Non-moving component
4	70	194	2	Grub*Screw*M5x16*ISO4026	C-85888			Mechanical	Non-moving component
4	80	195	8	Nordlock*WasherM6	C-86898		DM6.5/10.8X1.8	Mechanical	Non-moving component
4	90	196	4	Nordlock*WasherM8	C-86848		DM8.7/13.5X2.5	Mechanical	Non-moving component
4	100	197	2	Cylindrical*Pin6x12*ISO2338	C-81714		DM6X12	Mechanical	Non-moving component
4	110	198	8	Sliding*Bearing GSM-1618-15	C-87050		16X18X15	Mechanical	Moving component
4	120	199	2	Depositor*IT-X-AV	C-89634	IT02040084	103.5X28X18/3	Mechanical	Non-moving component
3	60	200		Locking*Bar*Left*compl.*IT-X-AV*DB	C-67007	IT02040220	147X125X40		Purely hierarchical categ.
4	10	201	1	Locking*Bracket*IT-02-AV	C-14868	IT02040024	125X99X40	Mechanical	Moving component
5	10	202		Flat*Bar100x40	C-70895		100X40		Blank part
4	20	203	1	Locking*Dogs*left*IT-02-AV	C-14869	IT02040025	40X30X25	Mechanical	Moving component
5	10	204		Flat*Bar40x30	C-70048		40X30		Blank part
4	30	205		Contact*Bolt*IT-X-AV*Left	C-67005	IT02040117	61.6X48X25		Purely hierarchical categ.
5	10	206	1	SheetforContact*Bolt*IT-X-AV*Left	C-90361	IT02040216	48X25/3	Mechanical	Non-moving component
5	20	207	1	Contact*Bolt	C-14923		V300331107	Mechanical	Moving component
6	10	208		Round*Bar8*drawnAndPolished	C-70107		RD8/H9		Blank part
5	30	209	1	Cylindrical*Pin8x14*ISO2338	C-86754		DM8X14	Mechanical	Non-moving component
4	40	210	1	Locking*Bolt*IT-02-AV	C-15030	IT02040051	RD8X95	Mechanical	Moving component
5	10	211		Round*Bar8*drawnAndPolished	C-70107		RD8/H9		Blank part
4	50	212	1	Sliding*Bearing GSM-0810-20	C-87145		8X10X20	Mechanical	Moving component
4	60	213	1	Countersunk*Screw*M5x10*ISO10642	C-80320			Mechanical	Non-moving component
4	70	214	1	Clamping*Pin3x16*ISO8752	C-80247		DM3X16	Mechanical	Non-moving component
4	80	215	1	Pressure*Spring*P117612	C-89492			Mechanical	Moving component
4	90	216	1	Insulating*Pipe*IT-02-AV	C-14871	IT02040026	DM12/2X38	Mechanical	Moving component
5	10	217		Plastic*Pipe12/ 8	C-70308		DM12/8		Blank part
4	100	218	1	Splint 2.5x25*ISO1234	C-81744		DM2,5X25	Mechanical	Non-moving component
		219							
4	110	220	1	U-washer8.4mm*ISO7089	C-80042		DM8.4	Mechanical	Non-moving component
3	70	221		Locking*Bar*Right*compl.*IT-X-AV*DB	C-67008	IT02040221	147X125X40		Purely hierarchical categ.
4	10	222	1	Locking*Bracket*IT-02-AV	C-14868	IT02040024	125X99X40	Mechanical	Moving component

Level	Item	Excel Line	No.	Name	Material No.	Drwg No.	Dimensions	Cat 1	Cat 2
5	10	223		Flat*Bar100x40	C-70895		100X40		Blank part
4	20	224	1	Locking*Dogs*Right*IT-02-AV	C-14870	IT02040029	40X30X25	Mechanical	Moving component
5	10	225		Flat*Bar40x30	C-70048		40X30		Blank part
4	30	226		Contact*Bolt*IT-X-AV*Right	C-67006	IT02040222	61.6X48X25		Purely hierarchical categ.
5	10	227	1	SheetforContactBolt*IT-X-AV*Right	C-90360	IT02040116	48X25/3	Mechanical	Non-moving component
5	20	228	1	Contact*Bolt	C-14923		V300331107	Mechanical	Moving component
6	10	229		Round*Bar8*drawnAndPolished	C-70107		RD8/H9		Blank part
5	30	230	1	Cylindrical*Pin8x14*ISO2338	C-86754		DM8X14	Mechanical	Non-moving component
4	40	231	1	Locking*Bolt*IT-02-AV	C-15030	IT02040051	RD8X95	Mechanical	Moving component
5	10	232		Round*Bar8*drawnAndPolished	C-70107		RD8/H9		Blank part
4	50	233	1	Sliding*Bearing*GSM-0810-20	C-87145		8X10X20	Mechanical	Moving component
4	60	234	1	Countersunk*Screw*M5x10*ISO10642	C-80320			Mechanical	Non-moving component
4	70	235	3	Clamping*Pin3x16*ISO8752	C-80247		DM3X16	Mechanical	Non-moving component
4	80	236	1	Pressure*Spring*P117612	C-89492			Mechanical	Moving component
4	90	237	1	Insulating*Pipe*IT-02-AV	C-14871	IT02040026	DM12/2X38	Mechanical	Moving component
5	10	238		Plastic*Pipe12/ 8	C-70308		DM12/8		Blank part
4	100	239	1	Splint 2.5x25*ISO1234	C-81744		DM2.5X25	Mechanical	Non-moving component
4	110	240	1	U-washer8.4mm*ISO7089	C-80042		DM8.4	Mechanical	Non-moving component
3	80	241		Flanged*Bush*complete	C-65985	241100002	RD78X26		Purely hierarchical categ.
						7			
4	10	242	4	Flanged*Bush*CSV24/PV	C-14606	241100011	DM60/35.5X24	Mechanical	Moving component
						9			
5	10	243		Round*Bar60*groundAndPolished	C-70103		RD60/H9		Blank part
4	20	244	4	Flange*Nut*CSV24/PV	C-14607	241100012	DM80/M52X13	Mechanical	Non-moving component
						0			
5	10	245		Round*Bar80*groundAndPolished	C-70768		RD80/H9		Blank part
4	30	246	4	Grooved*Ring	C-87992		35X43X6.3	Mechanical	Non-moving component
4	40	247	4	Wiper	C-87991		35X43X7	Hydraulic	Moving component
4	50	248	4	Guide*Belt*FB3,9-1,55	C-80388		3.9X1.55	Mechanical	Non-moving component
4	60	249	4	O-Ring47	C-87978		47X3	Hydraulic	Moving component
		250							
4	70	251	4	Grub*Screw*M5x10*ISO4026	C-80444			Mechanical	Non-moving component
3	90	252		Cylinder50/30compl.*Free*Fltg*IT-X-AV	C-67233	IT02060337	DM68X482		Purely hierarchical categ.
4	10	253	1	Cylinder*Pipe*IT-02-AV	C-14776	IT02060001	DM58X220	Mechanical	Non-moving component

Level	Item	Excel Line	No.	Name	Material No.	Drwg No.	Dimensions	Cat 1	Cat 2
5	10	254		Pipe(HP) 60x5*H8	C-70201		DM60/50		Blank part
4	20	255	1	Piston*Barrel*IT-02-AV	C-15068	IT02060039	DM30/20X482	Hydraulic	Non-moving component
5	10	256		Telescopic*Pipe 30x5.0*Dm30f7/20H9	C-71030		DM30/20		Blank part
4	30	257	1	Control*Rod*IT-02-AV	C-15063	IT02060009	DM20X54	Hydraulic	N/A, for motor only
5	10	258		Round*Bar22	C-70379		RD22		Blank part
4	40	259	2	Cylndr*HeadDm30*noVentilation*IT-X-AV	C-15858	IT02060336	DM68X46	Mechanical	Non-moving component
5	10	260		Round*Bar70*peeled	C-70106		RD70		Blank part
4	50	261	2	Pressure*Sleeve*IT-X	C-15067	IT02060056	DM19.5/15X88	Mechanical	Non-moving component
5	10	262		Pipe20x2,5 *seamless	C-70159		DM20X2,5		Blank part
4	60	263	1	Piston*Dm50/30-IT-02-AV	C-15127	IT02060061	DM49.4/30X18	Hydraulic	Moving component
5	10	264		Round*Bar50*peeled	C-70282		RD50		Blank part
4	70	265	2	Pressure*Ring*IT-02-AV	C-14784	IT02060004	DM70/58X27	Mechanical	Non-moving component
5	10	266		Round*Bar70	C-70703		RD70		Blank part
4	80	267	1	Sliding*Seal*Manoy*OMK-MR50-3.2	C-80389		50X42.5X3.2	Hydraulic	Moving component
4	90	268	2	Wiper 30x40x5/8	C-88090		30X40X5/8	Hydraulic	Moving component
4	100	269	2	Sealing*Ring30x40x11	C-88091		30X40X11	Hydraulic	Moving component
4	110	270	1	Guide*Belt*FB3.9-1.55	C-80388		3.9X1.55	Mechanical	Non-moving component
4	120	271	2	Shim*Ring/Support*Disc*SS30x42x2.5	C-88847		DM30/42X2.5	Mechanical	Non-moving component
4	130	272	2	Circlip*I20x1	C-82628		I 20X1	Mechanical	Non-moving component
4	140	273	2	Circlip*AS30x2	C-88845		AS30X2	Mechanical	Non-moving component
4	150	274	2	RVA-06*Non*Return*Valve	C-86445			Hydraulic	Moving component
4	160	275	1	O-Ring24	C-87821		24X1.5	Hydraulic	Moving component
4	170	276	2	O-Ring53	C-87406		DM53X2.5	Hydraulic	Moving component
4	180	277	2	Press*Spring*VD-313A-11*17-threaded	C-85210		3.3x19.5x115/17	Mechanical	Moving component
4	190	278	2	Cylindrical*Pin5x30*ISO2338	C-81890		DM5X30	Mechanical	Non-moving component
3	100	279		Electrical*Parts*Mechanics*IT-X-AV	C-66458	IT02050062			Purely hierarchical categ.
4	10	280	1	Cable*Set*IT-X-AV*Locking*Unit	C-89753	IT02050071		Electrical	Electrical subsystem
		281							
4	20	282	8	ISK*Screw*M4x16*ISO4762	C-80949			Mechanical	Non-moving component
4	30	283	8	U-Washer4,3mm*ISO7089	C-80452	DM4,3		Mechanical	Non-moving component
4	40	284	2	Flexible*Belt*FBB100*150-28100	C-82655	Hellermann		Mechanical	Non-moving component
4	50	285	4	ISK*Screw*M3x10*ISO4762	C-86747			Mechanical	Non-moving component
4	60	286	4	U-Washer3.2mm*ISO7089	C-82775	DM3,2		Mechanical	Non-moving component
4	70	287	2	Sticker*Safety*Marking	C-86280		25X25MM	Mechanical	Non-moving component

Level	Item	Excel Line	No.	Name	Material No.	Drwg No.	Dimensions	Cat 1	Cat 2
3	110	288	1	Insert*IT-02-AV	C-14877	IT02040033	150X35X15	Mechanical	Moving component
4	10	289	1	Flat*Bar40x30	C-70048		40X30		Blank part
3	120	290	2	Base1*IT-02-AV	C-88316	IT02040010	234X100X3	Mechanical	Non-moving component
3	130	291	1	Locking*Support*Left*IT-02-AV	C-14866	IT02040020	160X148X35	Mechanical	Moving component
4	10	292		Flat*Bar150x50	C-70866		150X50		Blank part
3	140	293	1	Locking*Support*Right*IT-02-AV	C-14865	IT02040019	160X148X35	Mechanical	Moving component
4	10	294		Flat*Bar150x50	C-70866		150X50		Blank part
3	150	295	2	Drive*Rod*DB*IT-02-AV	C-15968	IT02040261	RD35X300	Mechanical	Non-moving component
3	160	296	2	Detector*Rod*DB*IT-X-AV	C-15969	IT02040262	RD35X268	Mechanical	Non-moving component
3	170	297	2	Switch*Plate2*IT-X-AV*DB	C-90358	IT02040219	164X148X3	Electrical	Electrical component
3	180	298	2	Guide*Rod*IT-02-AV	C-14862	IT02040014	RD16X499	Mechanical	Moving component
4	10	299		Round*Bar16*DrawnandPolished	C-70301		RD16/H9		Blank part
3	190	300	2	Cylinder*Connector3*IT-X-AV*DB	C-15742	IT02060301	RD52X59	Mechanical	Non-moving component
4	10	301		Round*Bar60*peeled	C-70104		RD60		Blank part
3	200	302	2	Safety*Plate6*IT-X-AV	C-89747	IT02040096	118X41/1	Mechanical	Non-moving component
3	210	303	2	Safety*Plate8*IT-X-AV*DB	C-90340	IT02040122	55X45/2	Mechanical	Non-moving component
3	220	304	2	Plug*Holder2*IT-X-AV*DB	C-90359	IT02040215	79X69X20	Mechanical	Non-moving component
3	230	305	4	Comp*Spring*VD-115G*0.7X11.3X84.6	C-88512		0.7X11.3X84.6	Mechanical	Moving component
3	240	306	4	SK*Screw*M20x100	C-90575		M20X100	Mechanical	Non-moving component
3	250	307	1	VSTI3/8-ED-CF*Blanking*Plug	C-80333		G3/8"	Mechanical	Non-moving component
3	260	308	4	Nordlock*WasherM6	C-86898		DM6.5/10.8X1.8	Mechanical	Non-moving component
3	270	309	4	Nordlock*WasherM8	C-86848		DM8.7/13,5X2.5	Mechanical	Non-moving component
3	280	310	4	Nordlock*WasherM10	C-86928		DM10.7/16.6X2.5	Mechanical	Non-moving component
3	290	311	4	SK*Screw*M8x20*ISO4017	C-80129			Mechanical	Non-moving component
		312							
3	300	313	4	ISK*Screw*M10x16*ISO4762	C-82344		M10X16	Mechanical	Non-moving component
3	310	314	2	SK*Screw*M10x12*ISO4017	C-80105		M10X12	Mechanical	Non-moving component
3	320	315	4	SK*Screw*M6x16*ISO4017	C-80442			Mechanical	Non-moving component
3	330	316	4	Cylindrical*Pin10x36*ISO2338	C-80308		DM10X36	Mechanical	Non-moving component
3	340	317	4	Cylindrical*Pin8x20*ISO2338	C-80667		DM8X20	Mechanical	Non-moving component
3	350	318	2	O-Ring18.77	C-81058		18.77X1.78	Mechanical	Moving component
3	360	319	4	O-Ring12.42	C-81262		12.42X1.78	Mechanical	Moving component
3	370	320	2	Grub*Screw*M6x16*ISO4029	C-87681			Mechanical	Non-moving component
3	380	321	1	SK*Screw*M16x30*ISO4017	C-80369		M16X30	Mechanical	Non-moving component

Level	Item	Excel Line	No.	Name	Material No.	Drwg No.	Dimensions	Cat 1	Cat 2
3	390	322	1	U-Washer17mm*ISO7089	C-81928		DM17	Mechanical	Non-moving component
3	400	323	1	Spring*Washer16mm	C-84275		DM16	Mechanical	Moving component
3	410	324	2	Nordlock*WasherM10forSlottedHole	C-90848		DM10.7/21.0X2.5	Mechanical	Non-moving component
3	420	325	1	U-WasherMs*17mm*ISO7089	C-81795		DM17	Mechanical	Non-moving component
3	430	326	1	SK*Screw*M16x20*ISO4017	C-80691		M16X20	Mechanical	Non-moving component
3	440	327	4	Grub*Screw*M8x8*ISO4026	C-86243			Mechanical	Non-moving component
2	20	328		Mech.*Housing*Cover*compl.*IT-X-	C-67574	IT02040284	1000X297X57.2		Purely hierarchical categ.
3	10	329		Mech.*Housing*Cover*IT-X- AV*DB Cover*Plate*IT-X-AV	C-67573	IT02040282	1000X297X57.2	Mechanical	Non-moving component
4	10	330	1		C-91150	IT02040281	1000X297X57.2/ 3	Mechanical	Non-moving component
4	20	331	2	Cover*Plate*IT-X-AV	C-89717	IT02040088	288X54X5	Mechanical	Non-moving component
4	30	332	2	Cover*Plate2*IT-X-AV	C-91151	IT02040283	40X15X13/3	Mechanical	Non-moving component
3	20	333		Oil*Gauge*Window*SP100*IT-X-AV	C-89708- 1	IT02040103	100X45X11.5	Hydraulic	Non-moving component
4	10	334	1	Oil*Gauge*Window*SP100	C-89708	DUMICO	AUSSEN:100X45SICHTÖFFU NG:79X18		Blank part
3	30	335	12	ISK*Screw*M5x10*ISO4762	C-80516			Mechanical	Non-moving component
3	40	336	1	Anti*Slip*Coating*Self*Adhesive	C-90468	IT02010025	840X170	Mechanical	Non-moving component
3	50	337	1,00	Foam*Rubber*Seal	C-89895		30X3MM	Mechanical	Non-moving component
2	30	338		Electrical*Parts*IT-X-AV*Lock*DB	C-67080	IT02050073			Purely hierarchical categ.
3	10	339	1	Cable*Set*IT-X-AV*Locking*Unit*DB	C-90998	IT02050097		Electrical	Electrical subsystem
3	20	340	2	Switch*Plate*IT-X-AV	C-90472	IT02040115	140X130X5	Electrical	Electrical component
3	30	341	2	Insulation*Plate*For*Contact*Device	C-80319	336300000	98X58X1	Mechanical	Non-moving component
3	40	342	2	Centering*Pin*IT-02-AV	C-14867	IT02040022	RD16/12X16	Mechanical	Non-moving component
4	10	344		Round*Bar16*drawnAndPolished	C-70301	RD16/H9	1.4057		Blank part
3	50	345	2	SK*Screw*M5x16*ISO4017	C-80172			Mechanical	Non-moving component
3	60	346	2	U-Washer5.3mm*ISO7089	C-80159	DM5,3		Mechanical	Non-moving component
3	70	347	2	Serrated*Washer5.3mm*FormA	C-80475	DM5,3		Mechanical	Non-moving component
2	40	348	1	Threaded*WasherM56x1.5*IT-02-AV	C-14884	IT02040041	M56*1.5X10	Mechanical	Non-moving component
3	10	349		Round*Bar60*peeled	C-70104		RD60		Blank part
2	50	350	1	Bridge*IT-X-AV*DB	C-15743	IT02040218	223X34X23	Mechanical	Non-moving component
2	60	351	4	Spacer*Sleeve*DM17,8/12X20	C-15759	IT02040224	DM17.8/12X20	Mechanical	Non-moving component
3	10	352		Round*Bar20	C-70101		RD20		Blank part

Level	Item	Excel Line	No.	Name	Material No.	Drwg no.	Dimensions	Cat 1	Cat 2
2	70	353	2	Spacer*Sleeve*DM17,8/12X5	C-15761	IT02040226	DM17.8/12X5	Mechanical	Non-moving component
3	10	354		Round*Bar20	C-70101		RD20		Blank part
2	80	355	2	Spacer*Sleeve*DM17,8/12X3	C-15762	IT02040227	DM17.8/12X3	Mechanical	Non-moving component
3	10	356		Round*Bar20	C-70101		RD20		Blank part
2	90	357	2	Spacer*Sleeve*DM17,8/12X1	C-15763	IT02040228	DM17.8/12X1	Mechanical	Non-moving component
3	10	358		Round*Bar20	C-70101		RD20		Blank part
2	100	359	2	ISK*Screw*M12x60*ISO4762	C-90475		M12X60	Mechanical	Non-moving component
2	110	360	4	ISK*Screw*M4x12*ISO4762	C-81872			Mechanical	Non-moving component
2	120	361	4	SK*Screw*M10x20*ISO4017	C-80107		M10X20	Mechanical	Non-moving component
2	130	362	2	Countersunk*Screw*M8x16*ISO10642	C-90474			Mechanical	Non-moving component
2	140	363	23	Cup*Spring50X25.4X3	C-87166		50X25.4X3	Mechanical	Moving component
2	150	364	4	Nordlock*WasherM10	C-86928		DM10.7/16.6X2.5	Mechanical	Non-moving component
2	160	365	4	Spring*Washer 4mm	C-80511		DM4	Mechanical	Moving component
2	170	366	1	Cap*129616	C-87647	DB		Mechanical	Non-moving component
2	180	367	1	Fixing*Ring*116603	C-87648			Mechanical	Non-moving component
2	190	368	2	GE12LR-ED-OMD-CF*straightStudCoupling	C-80401		GE12LR-ED-OMD-CF	Mechanical	Non-moving component
2	200	369	1	DB-BuiltInLockwithLockingLug*red	C-88893			Mechanical	Non-moving component
2	210	370	1	Name*Plate*German	C-90883	IT02040254	35X84	Mechanical	Non-moving component
2	220	371	2	Blind*Rivet4x10	C-90417		DM4X10	Mechanical	Non-moving component
2	230	372	1	Seal*IT-X-AV*	C-90956	IT02040260	225X24/3	Mechanical	Non-moving component
1	30	373		U-Parts*IT-X-AV*insul.*1.SE*BA=173mm	C-66311	IT02020061	SPUR=1435		Purely hierarchical categ.
		374							
2	10	375	2	Tongue*Fork1	C-15044	IT02020016	126X83X76	Mechanical	Non-moving component
3	10	376		Flat*Bar130x80	C-70842		130X80		Blank part
2	20	377	2	Tongue*Fork2	C-15045	IT02020017	126X83X76	Mechanical	Non-moving component
3	10	378		Flat*Bar130x80	C-70842		130X80		Blank part
2	30	379	4	Bracket 2	C-15965	IT02021036	126X75X30	Mechanical	Non-moving component
3	10	380		Flat*Bar80x40	C-71059		80X40		Blank part
2	40	381	2	Rod*Enclosure 97mm	C-15913	IT02021025	DM56X97	Mechanical	Non-moving component
3	10	382		Round*Bar60*peeled	C-70104		RD60		Blank part
2	50	383	2	Pressure*Pin*M27	C-14782	IT02020004	DM45X96	Mechanical	Non-moving component
3	10	384		Round*Bar45	C-70810		RD45		Blank part
2	60	385	2	Pressure*Pin*M24	C-15391	IT02020066	DM45X146	Mechanical	Non-moving component

Level	Item	Excel Line	No.	Name	Material No.	Drwg No.	Dimensions	Cat 1	Cat 2
3	10	386		Round*Bar45	C-70810		RD45		Blank part
2	70	387	8	Insulated*Bracket 2*IT-X-AV	C-15960	IT02021031	36X36X27	Mechanical	Non-moving component
3	10	388		Flat*Material40x30	C-70838		40x30		Blank part
2	80	389	8	Bearing*BoltsSW22	C-14783	IT02020006	SW22/DM16X38	Mechanical	Non-moving component
3	10	390		Hexagon SW221.4057	C-71044		SKT22		Blank part
2	90	391	2	Retractor	C-14786	IT02020007	84X50X15	Mechanical	Non-moving component
3	10	392		Flat*Bar 50x20	C-70944		50X20		Blank part
2	100	393	2	Retractor3	C-15966	IT02021037	84X50X45	Mechanical	Non-moving component
3	10	394		Flat*Bar 90x60	C-70779		90X60		Blank part
2	110	395	2	Pressure*Cap2	C-15726	IT02021002	DM50/20X15	Mechanical	Non-moving component
2	120	396	4	Fixing*Cap*IT-X-AV	C-15390	IT02020064	DM46X16	Mechanical	Non-moving component
3	10	397		Round*Bar50*groundAndPolished	C-70649		RD50/H9		Blank part
2	130	398	4	Safety*Mechanism	C-88245	IT02020010	40X22X5	Mechanical	Non-moving component
2	140	399	2	Rod*Bolt*DM35/25	C-15789	IT02020140	RD35/25X67	Mechanical	Non-moving component
3	10	400		Round*Bar36	C-70368		RD36		Blank part
2	150	401	4	Eccentric*Bolt	C-15192	IT02020026	DM35/20X68.5	Mechanical	Non-moving component
3	10	402		Round*Bar35	C-70140		RD35		Blank part
2	160	403	2	Stud*Holder*long*Safety*Plate3mm	C-89705	IT02020069	57X25X3	Mechanical	Non-moving component
2	170	404	4	Cover2	C-15964	IT02021032	136X61X40	Mechanical	Non-moving component
		405							
3	10	406		Flat*Material150x60	C-70803		150x60		Blank part
2	180	407	4	Safety*Plate*for*Tongue*+*Fork*IT-X-AV	C-89529	IT02020063	59.5X32.5X30/3	Mechanical	Non-moving component
2	190	408	4	Square*Plate*IT-X-AV	C-89526	IT02020065	VKT.15X3	Mechanical	Non-moving component
2	200	409	2	Locking*Washer*IT-X-AV	C-89527	IT02020067	DM50X5/1	Mechanical	Non-moving component
2	210	410	4	ISK*Screw*M8x55-30*withTrunnion	C-89528	MISUMI		Mechanical	Non-moving component
2	220	411	4	SK*Screw*M12x16*ISO4017	C-80094		M12X16	Mechanical	Non-moving component
2	230	412	2	SK*Screw*M8x12*ISO4017	C-80128			Mechanical	Non-moving component
2	240	413	4	SK*Screw*M8x16*ISO4017	C-80079			Mechanical	Non-moving component
2	250	414	4	SK*Screw*M8x20*ISO4017	C-80129			Mechanical	Non-moving component
2	260	415	2	SK*Nut*Flat*M24*FormB*ISO4035	C-81587		M24	Mechanical	Non-moving component
2	270	416	2	SK*Nut*Flat*M27*FormB*ISO4035	C-80574		M27	Mechanical	Non-moving component
2	280	417	2	SK*Nut*Flat*M27*FormB*ISO4035	C-81926		M27	Mechanical	Non-moving component
2	290	418	14	Nordlock-WasherM8	C-86848		DM8.7/13.5X2.5	Mechanical	Non-moving component
2	300	419	8	Sliding*Bearing GFM-1618-21	C-87981		16X18X21	Mechanical	Non-moving component

Level	Item	Excel Line	No.	Name	Material No.	Drwg No.	Dimensions	Cat 1	Cat 2
2	310	420	8	Grub*Screw*M6x10*ISO4028	C-80311			Mechanical	Non-moving component
2	320	421	8	Nirosta-Thrust*Block*GN615.1-M6BSN	C-88990	GANTER	M6x14	Mechanical	Non-moving component
2	330	422	4	Tension*Bush*Eccentric*Dm32/24x20	C-80734		DM32/24X20	Mechanical	Non-moving component
2	340	423	4	Cylindrical*Pin4x16*ISO2338	C-89530		DM4X16	Mechanical	Non-moving component
2	350	424	4	Safety*Plate28mm*Washerwith Lobes	C-84577		DM28	Mechanical	Non-moving component
2	360	425	4	Safety*Plate*Dm13	C-85451		DM13	Mechanical	Non-moving component
1	40	426		Hydraulic*Unit*IT-X-AV*DB	C-65548	IT02060307	528X316X191		Purely hierarchical categ.
2	10	427		Hydraulic*Housing*IT-02-AV	C-65424	IT02060012	520X310X170		Purely hierarchical categ.
3	10	428	1	Housing*Trough*IT-02-AV	C-88333	IT02060013	544X520X5	Mechanical	Non-moving component
3	20	429	1	Head*Plate1*IT-02-AV	C-88334	IT02060014	310X160X5	Mechanical	Non-moving component
3	30	430	1	Head*Plate2Laser*Part*IT-02-AV	C-88335	IT02060015	310X170X5	Mechanical	Non-moving component
3	40	431	6	Capped*NutM16*tallForm	C-86618	M16	A2	Mechanical	Non-moving component
3	50	432	1	Grub*Screw*M8x16*ISO4026	C-83790			Mechanical	Non-moving component
3	60	433	1	Grub*Screw*M6x16*ISO4029	C-87681			Mechanical	Non-moving component
2	20	434		Hydraulic*Hsng*Cover*Plate*IT-X-AV*DB	C-67569	IT02060368	471X326X74.3	Mechanical	Non-moving component
3	10	435		Hydraulic*Hsng*Cover**IT-X-AV*DB	C-67568	IT02060367	471X326X75	Mechanical	Non-moving component
		436							
4	10	437	1	Cover*Pan 2*IT-02-AV	C-89663	IT02060158	467X326X75/2	Mechanical	Non-moving component
4	20	438	1	Side*Plate4*IT-02-AV	C-89647	IT02060156	314X70.3/2	Mechanical	Non-moving component
4	30	439	1	Side*Plate5*IT-02-AV	C-89662	IT02060157	314X70.3/2	Mechanical	Non-moving component
4	40	440	1	Track*IT-02-AV	C-89652	IT02060140	465X50X24/2	Mechanical	Non-moving component
4	50	441	2	Internal*Sheet1mm*forHydraulicCover	C-91140	IT02060366	172X25.2X10/1	Mechanical	Non-moving component
3	20	442	1	Anti*Slip*Coating-self-adhesive188x474	C-89573		SFS	Mechanical	Non-moving component
3	30	443	1	Foam*Rubber*Seal	C-89895		30X3MM	Mechanical	Non-moving component
2	30	444		Cover*IT-02-AV	C-65426	IT02060019	316X75X53		Purely hierarchical categ.
3	10	445	1	Cover*Pan*IT-02-AV	C-88338	IT02060020	392.4X49/2	Mechanical	Non-moving component
3	20	446	1	Side*Plate3*IT-02-AV	C-89646	IT02060139	314X70.3/2	Mechanical	Non-moving component
3	30	447	1	Side*Plate4*IT-02-AV	C-89647	IT02060156	314X70.3/2	Mechanical	Non-moving component
3	40	448	1	Locking*Mechanism*IT-02-AV	C-89648	IT02060142	30X15X15/2	Mechanical	Non-moving component
2	40	449		Hand*Pump*complete*IT-02-AV	C-65437	IT02060040			Purely hierarchical categ.
3	10	450		Control*Plate1complete*IT-02-AV	C-66000	IT02060080		Mechanical	N/A, for motor only
4	10	451	1	Control*Plate*IT-02-AV	C-14905	IT02060035	215X115X50	Mechanical	N/A, for motor only

Level	Item	Excel Line	No.	Name	Material No.	Drwg No.	Dimensions	Cat 1	Cat 2
5	10	452		Flat*Aluminium120x70	C-70263		120X70		Blank part
4	20	453	8	MB700-080*Sealing*Stopper(Expander)	C-80472		DM8	Mechanical	N/A, for motor only
3	20	454		Control*Plate2complete*IT-02-AV	C-66001	IT02060081		Mechanical	N/A, for motor only
4	10	455	1	Control*Plate2*IT-02-AV	C-14986	IT02060051	115X83X50	Mechanical	N/A, for motor only
5	10	456		Flat*Aluminium90x60	C-70405		90x60		Blank part
4	20	457	1	MB700-080*Sealing*Stopper(Expander)	C-80472		DM8	Mechanical	N/A, for motor only
4	30	458	2	O-Ring 9.25	C-86858		9.25X1.78	Hydraulic	N/A, for motor only
3	30	459	1	Control*Plate3*IT-02-AV	C-14987	IT02060052	115X105/10	Mechanical	N/A, for motor only
4	10	460		Flat*Aluminium120x10	C-70509		120X10		Blank part
3	40	461	1	Hand*Pump*Lever*IT-02-AV	C-14904	IT02060034	24X24X139	Mechanical	N/A, for motor only
4	10	462		Round*Bar36	C-70368		RD36		Blank part
3	50	463	1	Piston*IT-02-AV	C-14906	IT02060036	DM22X145	Mechanical	N/A, for motor only
4	10	464		Round*Bar25	C-70344		RD25		Blank part
3	60	465	1	Axle*IT-02-AV	C-14907	IT02060037	RD16X50	Mechanical	N/A, for motor only
4	10	466		Round*Bar16*drawnAndPolished	C-70301		RD16/H9		Blank part
		467							
3	70	468	3	VST11/4-ED-CF*Blanking*Plug	C-80234		G1/4"	Mechanical	N/A, for motor only
3	80	469	3	RVA-06*Non*Return*Valve	C-86445			Hydraulic	N/A, for motor only
3	90	470	1	RVB-06*Non*Return*Valve	C-80152	HYDROWER		Hydraulic	N/A, for motor only
3	100	471	1	Sliding*Bearing GFM-1214-24	C-87347		12X14X24	Hydraulic	N/A, for motor only
3	110	472	2	Quadring*QRAR04115	C-81690	Busak	17.12-2.62	Hydraulic	N/A, for motor only
3	120	473	2	ISK*Screw*M8x80*ISO4762	C-80016			Mechanical	Non-moving component
3	130	474	4	Countersunk*Screw*M8x20*ISO10642	C-80202			Mechanical	Non-moving component
3	140	475	2	Cylindrical*Pin8x20*ISO2338	C-80667		DM8X20	Mechanical	Non-moving component
3	150	476	1	MRV4-10N-D-0*4/3-way* Screw-in*Valve	C-81129	VICKERS		Hydraulic	N/A, for motor only
3	160	477	1	Knob*IT-02-AV	C-15170	IT02060066	RD40X22	Mechanical	N/A, for motor only
4	10	478		Round*Material 40	C-70155		RD40		Blank part
2	50	479		Hydraulic*UnitE2compl.*4l/min*IT-X-	C-67423	IT02060347	294X219X158		Purely hierarchical categ.
3	10	480		Pump*SupportEcompl.*IT-02-AV	C-65992	IT02060074			Purely hierarchical categ.
4	10	481	1	Pump*SupportE-2*IT-02-AV	C-15182	246101000	210X158X68	Mechanical	Non-moving component
						2			
5	10	482		Flat Aluminium160x80	C-70747		160X80		Blank part

Level	Item	Excel Line	No.	Name	Material No.	Drwg No.	Dimensions	Cat 1	Cat 2
4	20	483	27	MB700-070*Sealing*Stopper(Expander)	C-80473		DM7	Hydraulic	Non-moving component
3	20	484		Motor*FlangeE*IT-02-AV	C-15191	IT02060079	190X156X14.5	Mechanical	Non-moving component
4	10	485	1	Flat*Aluminium160x15	C-70267		160X15		Blank part
3	30	486		TankEcompl.*IT-02-AV*HoleforFillLevel	C-67422	IT02060346	210X158X118		Purely hierarchical categ.
4	10	487		TankE*IT-02-AV*HoleforFillLevelSensor	C-15923	IT02060339	210X158X118		Purely hierarchical categ.
5	10	488	1	TankE*IT-02-AV	C-14902	IT02060032	210X158X118	Hydraulic	Non-moving component
6	10	489		Flat Aluminium160x120	C-70746		160X120		Blank part
4	20	490	6	MB700-080*Sealing*Stopper(Expander)	C-80472		DM8	Hydraulic	Non-moving component
4	30	491	2	O-ring 9,25	C-86858		9.25X1.78	Hydraulic	Moving component
3	40	492		Control*PlateE*Compl.*IT-02-AV	C-65996	IT02060078			Purely hierarchical categ.
4	10	493	1	Hand*Pump*Control*PlateE	C-11938	246101001	50X50X12	Mechanical	Non-moving component
						0			
5	10	494		Flat Aluminium60x15	C-70684		60X15		Blank part
4	20	495	4	MB700-080*Sealing*Stopper(Expander)	C-80472		DM8	Hydraulic	Non-moving component
4	30	496	4	O-Ring 9.25	C-86858		9.25X1.78	Hydraulic	Moving component
3	50	497		Control*Block1 compl.*IT-02-AV	C-65993	IT02060075		Hydraulic	Non-moving component
		498							
4	10	499	1	Control*Block1*IT-02-AV	C-15178	IT02060070	134X70X42	Hydraulic	Non-moving component
5	10	500		Flat Aluminium75x45	C-70757		75X45		Blank part
4	20	501	7	MB700-080*Sealing*Stopper(Expander)	C-80472		DM8	Hydraulic	Non-moving component
4	30	502	4	O-Ring 9,25	C-86858		9.25X1.78	Hydraulic	Moving component
3	60	503		Control*Block2 complete*IT-02-AV	C-65994	IT02060076		Hydraulic	Non-moving component
4	10	504	1	Control*Block2*IT-02-AV	C-15177	IT02060069	134X70X42	Hydraulic	Non-moving component
5	10	505		Flat Aluminium75x45	C-70757		75X45		Blank part
4	20	506	8	MB700-080*Sealing*Stopper(Expander)	C-80472		DM8	Hydraulic	Non-moving component
4	30	507	4	O-ring 9,25	C-86858		9.25X1.78	Hydraulic	Moving component
3	70	508	2	Thrust*Block*Aggregate E*4l	C-15290	246310001	63X59X24	Mechanical	Non-moving component
						7			
4	10	509		Flat*Bar60x30	C-70774		60X30		Blank part
3	80	510	2	Hollow*Screw*SW30x45,5	C-10337	036610102	SKT30X45.5	Mechanical	Non-moving component
						0			
4	10	511		HexagonSW30*1.4307	C-70983		SKT30		Blank part
3	90	512	2	Hollow*Screw*SW24x78	C-10338	036610103	SKT24X78	Mechanical	Non-moving component
						0			
4	10	513		HexagonSW24*1.4307	C-70982		SKT24		Blank part

Level	Item	Excel Line	No.	Name	Material No.	Drwg No.	Dimensions	Cat 1	Cat 2
3	100	514	2	Oil*Gauge*Glass*ELESA*GN743.1-14-	C-87707			Hydraulic	N/A, for motor only
3	110	515	1	Gear*Pump*ALP1A-R-4-E1	C-88994		4L/MIN	Hydraulic	Moving component
3	120	516	1	O-Ring51	C-80863		51X3	Hydraulic	Moving component
3	130	517	1	O-Ring200	C-81936		200X3	Hydraulic	Moving component
3	140	518	4	Usit*Ring*DDM000174	C-80866			Mechanical	Moving component
3	150	519	4	Usit*Ring*DDM000207	C-80867			Mechanical	Moving component
3	160	520	2	RVB-06*Non*Return*Valve	C-80152	HYDROWE R		Hydraulic	Moving component
3	170	521	2	RVB-08*Non*Return*Valve	C-80868			Hydraulic	Moving component
3	180	522	2	VST11/4-ED-CF*Blanking*Plug	C-80234		G1/4"	Hydraulic	Non-moving component
3	190	523	2	SPC2-10-N-P-O-100*Non*Return*Valve	C-80335			Hydraulic	Moving component
3	200	524	2	VST13/8-ED-CF*Blanking*Plug	C-80333		G3/8"	Hydraulic	Non-moving component
3	210	525	2	Double*Nipple*G3/8-G3/8-252.03	C-80869			Hydraulic	Non-moving component
3	220	526	2	Suction*Filter*40466-250µm	C-80609		40X80	Hydraulic	Non-moving component
3	230	527	2	Valve RV1-10N-C-0- 18*ABCOTypeMO4/16	C-80336	VICKERS/FREMAC		Hydraulic	Moving component
3	240	528 529	2	Pressure*Transducer250bar*455-4680	C-90870	RSCOMPONENTS		Hydraulic	N/A, for motor only
3	250	530	1	Locking*Screw*GN747G1/2-A-2	C-83097		G1/2"	Mechanical	Non-moving component
3	260	531	1	Connector*PieceM*DentexB24.19H7	C-80873			Mechanical	Non-moving component
3	270	532	1	Connector*PieceP*DentexB24.TA	C-80874			Mechanical	Non-moving component
3	280	533	1	Connector*Sleeve*DentexB24	C-80875			Mechanical	Non-moving component
3	290	534	4	ISK*Screw*M6x12*ISO4762	C-80005			Mechanical	Non-moving component
3	300	535	8	ISK*Screw*M8x45*ISO4762	C-80012			Mechanical	Non-moving component
3	310	536	4	ISK*Screw*M8x100*ISO4762	C-80258			Mechanical	Non-moving component
3	320	537	3	ISK*Screw*M8*Inbus Ripp	C-80877			Mechanical	Non-moving component
3	330	538	2	SK*Screw*M8x25*ISO4017	C-80054			Mechanical	Non-moving component
3	340	539	2	Cylindrical*Pin8x20*ISO2338	C-80667		DM8X20	Mechanical	Non-moving component
3	350	540	2	U-Washer8.4mm*ISO7089	C-80042		DM8.4	Mechanical	Non-moving component
3	360	541	2	Level*SwitchLLE102000*477-4676	C-90871	RSCOMPONENTS		Hydraulic	N/A, for motor only
2	60	542		Closing*Mechanism*IT-X-AV*DB	C-66127	IT02060093			Purely hierarchical categ.
3	10	543	1	Switch*Block	C-15271	IT02050024	105X65X30	Mechanical	N/A, for motor only
4	10	544		Flat*Aluminium105x65	C-70547		105X65		Blank part
3	20	545	1	Closing*Plate*lasered	C-89200	IT02050028	370X67X44/3	Mechanical	Non-moving component

Level	Item	Excel Line	No.	Name	Material No.	Drwg No.	Dimensions	Cat 1	Cat 2
3	30	546	1	Switch*Shaft	C-15269	IT02050023	RD16X73	Mechanical	N/A, for motor only
4	10	547		Round*Bar16*drawnAndPolished	C-70301		RD16/H9		Blank part
3	40	548	2	Switch*Cam	C-15270	IT02050026	25X20X19	Mechanical	N/A, for motor only
4	10	549		Flat*Aluminium30x20	C-70404		30X20		Blank part
3	50	550		Lever*Complete	C-66113	IT02050041	46X25X8		Purely hierarchical categ.
4	10	551	1	Lever*Plate*lasered	C-89199	IT02050027	46X25X5	Mechanical	N/A, for motor only
4	20	552	1	Cylindrical*Pin8x12*ISO2338	C-81728		DM8X12	Mechanical	N/A, for motor only
3	60	553		Locking*Wheel	C-15266	IT02050031	RD55/36X15	Mechanical	Non-moving component
4	10	554		Round*Material 55	C-70553		Rd55		Blank part
3	70	555	1	Locking*Box	C-15267	IT02050030	RD43/22X25	Mechanical	Non-moving component
4	10	556		Round*Bar45*groundAndPolished	C-70299		RD45/H9		Blank part
3	80	557	1	Closing*Disc	C-15268	IT02050029	RD54/43X16	Mechanical	Non-moving component
4	10	558		Round*Material 55	C-70553		Rd55		Blank part
3	90	559	1	Support*Sheet*lasered	C-89201	IT02050038	100X97X8,5/3	Mechanical	Non-moving component
3	100	561	1	Cam*Angle*lasered	C-89203	IT02050033	30X26X20X3	Mechanical	Non-moving component
3	110	562	1	Locking*Pin	C-15265	IT02050032	VKT8X81	Mechanical	Non-moving component
4	10	563		Square 8	C-71037		VKT8		Blank part
3	120	564	1	Cap*IT-X-AV*lasered	C-89253	IT02050039	32X22X2	Mechanical	Non-moving component
3	130	565	4	ISK*Screw*M4x20*ISO4762	C-86629			Mechanical	Non-moving component
3	140	566	2	SK*Screw*M6x12*ISO4017	C-80154			Mechanical	Non-moving component
3	150	567	2	SK*Screw*M6x16*ISO4017	C-80442			Mechanical	Non-moving component
3	160	568	1	Countersunk*Screw*M4x8*ISO10642	C-88532			Mechanical	Non-moving component
3	170	569	2	Countersunk*Screw*M5x10*ISO10642	C-80320			Mechanical	Non-moving component
3	180	570	2	Countersunk*Screw*M6x12*ISO10642	C-80074			Mechanical	Non-moving component
3	190	571	2	Tensioning*Pin4x20*ISO8752	C-82725		DM4X20	Mechanical	Non-moving component
3	200	572	2	Grub*Screw*M6x10*ISO4028	C-80311			Mechanical	Non-moving component
3	210	573	4	Nordlock*WasherM6	C-86898		DM6.5/10.8X1.8	Mechanical	Non-moving component
3	220	574	1	Cylindrical*Pin8x20*ISO2338	C-80667		DM8X20	Mechanical	Non-moving component
3	230	575	1	DB-BuiltInLockwithLockingLug*grey	C-88987	ASSA ABLOY		Mechanical	N/A, for motor only
2	70	576	1	Head*Sheet4*IT-02-AV	C-89638	IT02060155	310X119X5	Mechanical	Non-moving component
2	80	577	1	Angle of traction*IT-x-AV	C-15489	IT02060165	50X20X25	Mechanical	Non-moving component
3	10	578		Angle50/30x5	C-70309		50X30X5		Blank part
2	90	579	1	Hydraulic*Pipe*IT-02-AV	C-15486	IT02060164	DM12X1.5X255	Hydraulic	Non-moving component

Level	Item	Excel Line	No.	Name	Material No.	Drwg No.	Dimensions	Cat 1	Cat 2
3	10	580		Hydraulic*Pipe12x1.5	C-70311		DM12X1,5		Blank part
2	100	581	1	Strike*Plate*lasered	C-90473	IT02060305	70X61.2X40/3	Mechanical	Non-moving component
2	110	582	1	Setting*Lever*compl.*HydraulicIT-X-AV	C-67459	IT02060345			Purely hierarchical categ.
3	10	583	1	Setting*Lever*short*HydraulicIT-X-AV	C-15956	IT02060352	DM20/16X495	Mechanical	N/A, for motor only
4	10	584		Pipe20x2*welded	C-70575		DM20X2		Blank part
3	20	585	1	Crowbar*with*Roller*Head*75 9810	C-90945	GÖDDE	DM14LÄNGE: 390MM	Mechanical	N/A, for motor only
2	120	586	2	GE12LR-ED-OMD- CF*straightScrewedConnection	C-80401		GE12LR-ED- OMD-CF	Mechanical	Non-moving component
2	130	587	2	SV 12- LCF*OMD*straightBulkheadConnection	C-80431			Mechanical	Non-moving component
2	140	588	2	VST13/8-ED-CF*Blanking*Plug	C-80333		G3/8"	Mechanical	Non-moving component
2	150	589	4	FM 12-LSSA*Function*Nut	C-80280		FM12-LSSA	Mechanical	Non-moving component
2	160	590	1	O-Ring15.6	C-87976		15.6X1.78	Hydraulic	Non-moving component
2	170	592	2	O-Ring12,42	C-81262		12.42X1.78	Hydraulic	Non-moving component
2	180	593	1	Fixing*Ring*116603	C-87648			Mechanical	Non-moving component
2	190	594	1	Cap*129616	C-87647		DB	Mechanical	Non-moving component
2	200	595		Electrical*Parts*Hydr.*Unit*IT-X-AV*DB	C-65549		EP08100801		
3	10	596	1	Cable*Set*IT-X-AV*Hydr.*Unit*DB	C-90493		IT02050088	Electrical	Electrical subsystem
3	20	597	1	SquarewithM8*50lg.	C-12705	241660000 0	25X25X50	Mechanical	Non-moving component
4	10	598		Square25	C-70378	VKT25	1.4301		Blank part
3	30	599	1	Spacer*Ring	C-10057	361050900	DM28/19.2X15	Mechanical	Non-moving component
4	10	600		Pipe28x5*seamless	C-70165		DM28X5		Blank part
3	40	601	1	E- motor*400VAC*0.75KW*1400Rpm*B14- kl. F	C-80264		DREHSTROM	Electrical	Electrical component
3	50	602	2	Blanking*Plug*with*O-RingM32x1.5	C-85241	Pflitsch	M32*1.5	Mechanical	Non-moving component
3	60	603	2	Cable*Screw*UNISeal*23254d1 6	C-86237	PFLITSCH	M32*1.5	Mechanical	Non-moving component
3	70	604	1	Housing*low-pol	C-89725	HARTING		Mechanical	Non-moving component
3	80	605	4	Countersunk*Screw*M6x16*ISO10642	C-80060			Mechanical	Non-moving component
3	90	606	8	ISK*Screw*M4x16*ISO4762	C-80949			Mechanical	Non-moving component
3	100	607	18	U-Washer4.3mm*ISO7089	C-80452		DM4.3	Mechanical	Non-moving component

Level	Item	Excel Line	No.	Name	Material No.	Drwg No.	Dimensions	Cat 1	Cat 2
3	110	608	1	U-Washer6.4mm*ISO7089	C-80041		DM6.4	Mechanical	Non-moving component
3	120	609	18	Serrated*Washer4.3mm*FormA	C-80945		DM4.3	Mechanical	Non-moving component
3	130	610	2	Serrated*Washer6.4mm*FormA	C-80075		DM6.4	Mechanical	Non-moving component
3	140	611	1	SK*Nut*M6*ISO4032	C-80029			Mechanical	Non-moving component
3	150	612	10	Cable*Tie100mm	C-80619		100X2.5 black	Mechanical	Non-moving component
3	160	613	1	Cable*Screw*Kleinhuis*M20*123 4M20	C-83821	Kleinhuis	M20*1.5	Mechanical	Non-moving component
3	170	614	1	Cable*Oil*Flex* 7x1.5mm ² *halogen-free	C-86770		7X1.5MM ²	Electrical	Electrical component
3	180	615	4	ISK*Screw*M4x20*ISO4762	C-86629			Mechanical	Non-moving component
3	190	616	2	Sealing*InsertPG21*E154/13*FC	C-80780	Pflitsch	PG21	Mechanical	Non-moving component
3	200	617	2	Sealing*InsertPG21*E154/18*FC	C-80754	PFLITSCH	PG21	Mechanical	Non-moving component
3	210	618	2	ISK*Screw*M5x12*ISO4762	C-80908			Mechanical	Non-moving component
3	220	619	7	Crimp*Sleeve*1.5 ² *insulated*black	C-80610		1,5M	Electrical	Electrical component
3	230	620	2	Sealing*Washer*949/21HKL	C-80679		PG21	Mechanical	Non-moving component
3	240	621	3	Sticker*Safety*Label	C-86280		25X25M	Mechanical	Non-moving component
		622							
2	210	623	4	ISK*Screw*M4x12*ISO4762	C-81872			Mechanical	Non-moving component
2	220	624	2	SK*Screw*M4x10*ISO4017	C-80508			Mechanical	Non-moving component
2	230	625	3	ISK*Screw*M10x50*ISO4762	C-80026		M10X50	Mechanical	Non-moving component
2	240	626	2	SK*Screw*M8x16*ISO4017	C-80079			Mechanical	Non-moving component
2	250	627	1	SK*Screw*M16x30*ISO4017	C-80240		M16X30	Mechanical	Non-moving component
2	260	628	2	U-Washer17mm*ISO7089	C-80045		DM17	Mechanical	Non-moving component
2	270	629	2	Nordlock-WasherM8	C-86848		DM8.7/13.5X2.5	Mechanical	Non-moving component
2	280	630	3	Spring*Ring 4mm	C-80511		DM4	Mechanical	Non-moving component
2	290	631	1	Spring*Ring16mm	C-80049		DM16	Mechanical	Non-moving component
2	300	632	1	DB-BuiltInLockwithLockingLug*red	C-88893			Mechanical	Non-moving component
2	310	633	1	Sign*Hydraulic	C-89784	IT02060163	191X40/2	Mechanical	Non-moving component
2	320	634		Hinge*Angle*Coupling*IT-X-AV	C-66401	IT02060146	42X25X14		Purely hierarchical categ.
3	10	635	2	Hinge*Angle	C-89655	IT02060145	42X25X14/2	Mechanical	Non-moving component
3	20	636	2	Hinge*Pin	C-15439	IT02060144	RD6X42	Mechanical	N/A, nur für Motor
4	10	637		Round*Bar6	C-70862		RD6		Blank
2	330	638	1	Hinge*Plate*IT-02-AV	C-89653	IT02060141	40X15/3	Mechanical	N/A, nur für Motor
2	340	639	4	SK*Screw*M6x12*ISO4017	C-80154			Mechanical	Non-moving component
2	350	640	4	SK*Screw*M10x20*ISO4017	C-80107		M10X20	Mechanical	Non-moving component

Level	Item	Excel Line	No.	Name	Material No.	Drwg No.	Dimensions	Cat 1	Cat 2
2	360	641	2	SK*Screw*M6x16*ISO4017	C-80442			Mechanical	Non-moving component
2	370	642	2	SK*Nut*M5*ISO4032	C-80220			Mechanical	Non-moving component
2	380	643	4	SK*Nut*M6*ISO4032	C-80029			Mechanical	Non-moving component
2	390	644	2	SK*Nut*Standalone*M5*ISO10511	C-86643			Mechanical	Non-moving component
2	400	645	2	U-Washer6.4mm*ISO7089	C-80041		DM6.4	Mechanical	Non-moving component
2	410	646	2	Nordlock-WasherM10	C-86928		DM10.7/16.6X2,5	Mechanical	Non-moving component
2	420	647	1	Anti*Slip*Coating*Self*Adhesive188x48	C-89574		188X48	Mechanical	Non-moving component
2	430	648	2	SK*Nut*Standalone*M6*ISO10511	C-85215			Mechanical	Non-moving component
2	440	649	1	Hinge*218-9002	C-85746		40X40	Mechanical	Non-moving component
2	450	650	2	U-Washer4.3mm*ISO7089	C-80452		DM4.3	Mechanical	Non-moving component
2	460	651	1	Locking*Bolt*for*DB*BuiltInLock	C-15955	IT02060343	46X20X18.5	Mechanical	N/A, for motor only
3	10	652		Square20	C-70213		Vkt20		Blank part
		653							
2	470	654	1	Name*Plate*German	C-90883	IT02040254	35X84	Mechanical	Non-moving component
2	480	655	2	Blind*Rivet4x10	C-90417		DM4X10	Mechanical	Non-moving component
2	490	656	2	ISK*Screw*M4x8*ISO4762	C-81593			Mechanical	Non-moving component
2	500	657	2	Nordlock-WasherM4F	C-87673		DM4.4/9.0X1.8	Mechanical	Non-moving component
2	510	658		Evaluation*Board*compl.*PMS12	C-67609	IT02050126	119X112X44		Purely hierarchical categ.
3	10	659		Electr*Housing*110x82x40mm*milled	C-16017	IT02050127	112.5X84.6X44	Mechanical	Non-moving component
4	10	660	1	Electr*Housing*110x82x40mm*493-6127	C-91203	RSC. (HAMMON D)	110X82X40MM		Blank part
3	20	661	1	Circuit*Board*PMS12	C-90881	GEFAS		Electrical	Electrical component
3	30	662	1	Bracket*for*Evaluation*Board compl.	C-91205	IT02050128	135X81X49/2	Mechanical	Non-moving component
3	40	663	2	Countersunk*Screw*M6x16*ISO10642	C-80060			Mechanical	Non-moving component
3	50	664	1	Spring*Strip*Harting*09062483201	C-91216	HARTING	DIN41612- F48FC-B	Electrical	Electrical component
3	60	665	2	Spacer*Slve*6-edge*M3*10mm*DA10mm	C-91274	REICHELT	M3 10MM	Mechanical	Non-moving component
3	70	666	2	Spring*Ring 3mm	C-81934		Dm3	Mechanical	Non-moving component
3	80	667	2	SK*Nut*M3*ISO4032	C-80948			Mechanical	Non-moving component
3	90	668	2	Countersunk*Screw*M2,5x8*ISO10642	C-91279			Mechanical	Non-moving component
3	100	669	2	Countersunk*Screw*M3x6*ISO10642	C-91278			Mechanical	Non-moving component
3	110	670	32	Individual*Contacts*Harting*09060008472	C-91217	HARTING		Electrical	Electrical component
1	50	671	1	Connector*Cable*Hydr.-Mech.	C-90997	IT02050103		Electrical	N/A, for motor only

Level	Item	Excel Line	No	Name	Material No.	Drwg No.	Dimension	Cat 1	Cat 2
1	60	672	1	Hydraulic*Pipe*Set*IT-X-AV*S49	C-67079	IT02060308	2-PARTS		Purely hierarchical categ.
2	10	673	1	Hydraulic*Pipe1*IT-X-AV	C-15780	IT02060310	DM12X1.5X974	Hydraulic	Non-moving component
3	10	674		Hydraulic*Pipe12x1,5	C-70956		DM12X1.5		Blank part
2	20	675	1	Hydraulic*Pipe2*IT-X-AV	C-15781	IT02060309	DM12X1.5X1654	Hydraulic	Non-moving component
3	10	676		Hydraulic*Pipe12x1,5	C-70956		DM12X1.5		Blank part
2	30	677	2	FM12-LSSA*Function*Nut	C-80280		FM12-LSSA	Mechanical	Non-moving component
1	70	678	1	Bridging*Connector*ITX-AV Sao Paulo	C-90014	IT02050069		Electrical	Electrical component
1	80	679	3	Compression*Cable*Lugs70mm²/M16	C-86163		70MM²/M16	Electrical	Electrical component
1	90	680	1	Compression*Cable*Lugs70mm²/M12	C-86161		70MM²/M12	Electrical	Electrical component
1	100	681	1	Double*Contact*SDK02	C-62641			Electrical	Electrical component
1	110	682	3	Cable-H07RN-F70mm²	C-86005		70MM²	Electrical	Electrical component
1	120	683	4	SFK1*S49/54*1x15-22mm	C-81635	2110-81635	30X1X226/125	Mechanical	Non-moving component
		684							
2	10	685		Flat*Belt*steel30x1	C-70516		30X1		Blank part

Page 12 - Figure 3 - Annotations

German	English
Schrauben mit Sicherung durch Nord-Lock-Scheiben müssen mit Graphit-Paste eingesetzt werden. Die Anzugsmomente müssen eingehalten werden!	<i>Screws secured with Nord-Lock washers must be installed using with graphite paste. All tightening torques must be observed.</i>
Flächen mit Lackfarbe neongelb füllen	<i>Fill areas with neon yellow paint</i>
Fertigungsfreigabe	<i>Release to manufacturing</i>
Datum	<i>Date</i>
Unterschrift	<i>Signature</i>
Weichenantrieb	<i>Switch drive</i>
Maße ohne Toleranzangabe:	<i>Dimensions specified without tolerances</i>
Werkstückkanten	<i>Work-piece edges</i>
Datum	<i>Date</i>
Name	<i>Name</i>
Bearb.	<i>Proc. By</i>
Stand	<i>Status</i>
Norm	<i>Norm</i>
Oberfläche	<i>Surface</i>
Toleranzklasse	<i>Tolerance class</i>
mittel	<i>Mean</i>
Maßstab	<i>Scale</i>
Art-Nr	<i>Prod. no.</i>
Material	<i>Material</i>
Rohmaß	<i>Raw measure</i>
Gewicht	<i>Weight</i>
Benennung	<i>Name</i>
Zeichnungsnummer	<i>Drawing no.</i>
Blatt	<i>Sheet</i>

Page 32 – Fault tree

German	English
Nach erfolgter Stellanforderung: Weichensteller ist nicht in Endlage. Dennoch wird Endlage gemeldet. Ergebnis nach 2190 h (3 Monate)	<i>Following switch request, switch machine is not in end position. System reports end position was achieved. Result after 2190 h (3 months)</i>
Hydraulikausfall	<i>Hydraulic failure</i>
Elektromotorausfall	<i>Electric motor failure</i>
Mechanik + Schalter	<i>Mechanical + switches</i>
Einzelausfall in Stellebene	<i>Individual failure in drive system</i>
Einzelausfall in Prüfebene	<i>Individual failure in detection system</i>
Ausfall erster Schnappschalter (von 8)	<i>Failure of first snap-action switch (of 8)</i>
Ausfall zweiter Schnappschalter (von 8)	<i>Failure of second snap-action switch (of 8)</i>
Ausfall dritter Schnappschalter (von 8)	<i>Failure of third snap-action switch (of 8)</i>
Ausfall vierter Schnappschalter (von 8)	<i>Failure of fourth snap-action switch (of 8)</i>
Mechanik + Verkabelung	<i>Mechanical + cabling</i>
Einzelausfall in Stellebene	<i>Individual failure in drive system</i>
Einzelausfall in Prüfebene	<i>Individual failure in detection system</i>
Einzelfehler in Verkabelung	<i>Individual fault in cabling</i>

Page 34 – Fault tree – as previous page, except

German	English
Nach erfolgter Stellanforderung: Weichensteller ist nicht in Endlage. Dennoch wird Endlage gemeldet. Ergebnis nach 4380 h (6 Monate)	<i>Following switch request, switch machine is not in end position. System reports end position was achieved. Result after 4380 h (6 months)</i>

Page 36 – Fault tree – as previous page, except

German	English
Nach erfolgter Stellanforderung: Weichensteller ist nicht in Endlage. Dennoch wird Endlage gemeldet. Ergebnis nach 9760 h (12 Monate)	<i>Following switch request, switch machine is not in end position. System reports end position was achieved. Result after 8760 h (12 months)</i>

Page 38 – Fault tree – as previous page, except

German	English
Nach erfolgter Stellanforderung: Weichensteller ist nicht in Endlage. Dennoch wird Endlage gemeldet. Ergebnis nach 17520 h (24 Monate)	<i>Following switch request, switch machine is not in end position. System reports end position was achieved. Result after 17520 h (24 months)</i>